

CANCO[®] **FASTENERS**

Trusted Name in Quality Fixing Systems



International Catalogue

PRODUCT GUIDE

HEAVY DUTY ANCHORS

- CAN BOLT
- CAN PROJECTION BOLT
- CAN EYE & HOOK BOLT
- CHEMICAL CAPSULE
- CAN THRU BOLT
- CAN SAFETY ANCHOR



Page.

| | CRACKED ZON CONCRETE | UN CRACKED CONCRETE | BRICK SOLID | BRICK PERFOATED | LIGHTWEIGHT CONCRETE | AERATED BLOCK | SANDSTONE | GRANITE | HOLLOW BLOCK | HOLLOW CLAY POT | PLASTERBOARD | PLYWOOD | HOLLOW DOOR |
|---|----------------------|---------------------|-------------|-----------------|----------------------|---------------|-----------|---------|--------------|-----------------|--------------|---------|-------------|
| 1 | Ⓢ | Ⓢ | Ⓢ | Ⓢ | Ⓢ | Ⓢ | Ⓢ | Ⓢ | Ⓢ | Ⓢ | Ⓢ | Ⓢ | Ⓢ |
| 2 | Ⓢ | Ⓢ | Ⓢ | Ⓢ | Ⓢ | Ⓢ | Ⓢ | Ⓢ | Ⓢ | Ⓢ | Ⓢ | Ⓢ | Ⓢ |
| 3 | Ⓢ | Ⓢ | Ⓢ | Ⓢ | Ⓢ | Ⓢ | Ⓢ | Ⓢ | Ⓢ | Ⓢ | Ⓢ | Ⓢ | Ⓢ |
| 4 | Ⓢ | Ⓢ | Ⓢ | Ⓢ | Ⓢ | Ⓢ | Ⓢ | Ⓢ | Ⓢ | Ⓢ | Ⓢ | Ⓢ | Ⓢ |
| 5 | Ⓢ | Ⓢ | Ⓢ | Ⓢ | Ⓢ | Ⓢ | Ⓢ | Ⓢ | Ⓢ | Ⓢ | Ⓢ | Ⓢ | Ⓢ |
| 6 | Ⓢ | Ⓢ | Ⓢ | Ⓢ | Ⓢ | Ⓢ | Ⓢ | Ⓢ | Ⓢ | Ⓢ | Ⓢ | Ⓢ | Ⓢ |

GENERAL FIXING ANCHORS

- CAN SLEEVE ANCHOR
- CAN HAMMER DRIVER ANCHOR
- CAN DROP-IN-ANCHOR
- CAN FRAME FIXING



7
8
9
10

| | | | | | | | | | | | | | |
|----|---|---|---|---|---|---|---|---|---|---|---|---|---|
| 7 | Ⓢ | Ⓢ | Ⓢ | Ⓢ | Ⓢ | Ⓢ | Ⓢ | Ⓢ | Ⓢ | Ⓢ | Ⓢ | Ⓢ | Ⓢ |
| 8 | Ⓢ | Ⓢ | Ⓢ | Ⓢ | Ⓢ | Ⓢ | Ⓢ | Ⓢ | Ⓢ | Ⓢ | Ⓢ | Ⓢ | Ⓢ |
| 9 | Ⓢ | Ⓢ | Ⓢ | Ⓢ | Ⓢ | Ⓢ | Ⓢ | Ⓢ | Ⓢ | Ⓢ | Ⓢ | Ⓢ | Ⓢ |
| 10 | Ⓢ | Ⓢ | Ⓢ | Ⓢ | Ⓢ | Ⓢ | Ⓢ | Ⓢ | Ⓢ | Ⓢ | Ⓢ | Ⓢ | Ⓢ |

CAN LIGHT FIXING ANCHOR

- CAN BRASS ANCHOR
- CAN NAIL PLUG
- CAN SPRING TOGGLE
- CAN PLASTIC PLUG
- CAN HIT PIN ANCHOR
- CEILING ANCHOR
- CEILING WIRE HANGER



11
11
12
12
13
13
13

| | | | | | | | | | | | | | |
|----|---|---|---|---|---|---|---|---|---|---|---|---|---|
| 11 | Ⓢ | Ⓢ | Ⓢ | Ⓢ | Ⓢ | Ⓢ | Ⓢ | Ⓢ | Ⓢ | Ⓢ | Ⓢ | Ⓢ | Ⓢ |
| 11 | Ⓢ | Ⓢ | Ⓢ | Ⓢ | Ⓢ | Ⓢ | Ⓢ | Ⓢ | Ⓢ | Ⓢ | Ⓢ | Ⓢ | Ⓢ |
| 12 | Ⓢ | Ⓢ | Ⓢ | Ⓢ | Ⓢ | Ⓢ | Ⓢ | Ⓢ | Ⓢ | Ⓢ | Ⓢ | Ⓢ | Ⓢ |
| 12 | Ⓢ | Ⓢ | Ⓢ | Ⓢ | Ⓢ | Ⓢ | Ⓢ | Ⓢ | Ⓢ | Ⓢ | Ⓢ | Ⓢ | Ⓢ |
| 13 | Ⓢ | Ⓢ | Ⓢ | Ⓢ | Ⓢ | Ⓢ | Ⓢ | Ⓢ | Ⓢ | Ⓢ | Ⓢ | Ⓢ | Ⓢ |
| 13 | Ⓢ | Ⓢ | Ⓢ | Ⓢ | Ⓢ | Ⓢ | Ⓢ | Ⓢ | Ⓢ | Ⓢ | Ⓢ | Ⓢ | Ⓢ |
| 13 | | | | | | | | | | | | | |

CAN SELF-DRILLING ANCHORS

- SELF DRILLING SCREW
- CAN DRILL SCREW
- DRY WALL SCREWS
- CHIPBOARD SCREWS
- CONCRETE SCREW
- CONFIRMATIVE SCREW



14
15
16
17
18
18

| | | | | | | | | | | | | | |
|----|---|---|---|---|---|---|---|---|---|---|---|---|---|
| 14 | Ⓢ | Ⓢ | Ⓢ | Ⓢ | Ⓢ | Ⓢ | Ⓢ | Ⓢ | Ⓢ | Ⓢ | Ⓢ | Ⓢ | Ⓢ |
| 15 | | | | | | | | | | | | | |
| 16 | | | | | | | | | | | | | |
| 17 | | | | | | | | | | | | | |
| 18 | | | | | | | | | | | | | |
| 18 | | | | | | | | | | | | | |

PIPE FITTINGS

- DIN3570 U BOLT
- CAN U CIAMP
- CAN SPRINKLER HANGER
- CAN PIPE CLAMP WITH RUBBER CPCR
- CAN PIPE CLAMP CPC

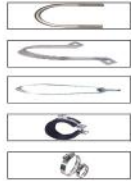

19
20
20
21
21

| | | | | | | | | | | | | | |
|----|---|---|--|--|--|--|--|--|--|--|--|--|--|
| 19 | Ⓢ | Ⓢ | | | | | | | | | | | |
| 20 | Ⓢ | | | | | | | | | | | | |
| 20 | Ⓢ | | | | | | | | | | | | |
| 21 | Ⓢ | | | | | | | | | | | | |
| 21 | Ⓢ | | | | | | | | | | | | |

- STONE CLADDING CLAMP



22

| | | | | | | | | | | | | | |
|----|---|--|--|--|--|--|--|--|--|--|--|--|--|
| 22 | Ⓢ | | | | | | | | | | | | |
|----|---|--|--|--|--|--|--|--|--|--|--|--|--|

GENERAL FASTENER

- BOLT**
- DIN 931,933,603+555
- DIN 571,912,6921



23
24

| | | | | | | | | | | | | | |
|----|---|---|---|--|--|--|--|--|--|--|--|--|--|
| 23 | Ⓢ | Ⓢ | Ⓢ | | | | | | | | | | |
| 24 | Ⓢ | Ⓢ | Ⓢ | | | | | | | | | | |

NUT

- DIN 934,982,
- DIN 985,1587,986
- DIN 6923,315,6334,935

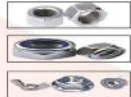

25
26
27

| | | | | | | | | | | | | | |
|----|---|---|---|--|--|--|--|--|--|--|--|--|--|
| 25 | Ⓢ | Ⓢ | Ⓢ | | | | | | | | | | |
| 26 | Ⓢ | Ⓢ | Ⓢ | | | | | | | | | | |
| 27 | Ⓢ | Ⓢ | Ⓢ | | | | | | | | | | |

WASHER

- DIN 125,7349
- DIN 126,9021,440
- DIN 127

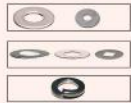

28
29
30

| | | | | | | | | | | | | | |
|----|---|---|---|--|--|--|--|--|--|--|--|--|--|
| 28 | Ⓢ | Ⓢ | Ⓢ | | | | | | | | | | |
| 29 | Ⓢ | Ⓢ | Ⓢ | | | | | | | | | | |
| 30 | Ⓢ | Ⓢ | Ⓢ | | | | | | | | | | |

THREDED ROD

- DIN 975 DIN 976
- ASTM STUD BOLT



31
31

| | | | | | | | | | | | | | |
|----|---|---|--|--|--|--|--|--|--|--|--|--|--|
| 31 | Ⓢ | Ⓢ | | | | | | | | | | | |
| 31 | | | | | | | | | | | | | |

- INDUSTRIAL SAFETY PRODUCTS



32

| | | | | | | | | | | | | | |
|----|--|--|--|--|--|--|--|--|--|--|--|--|--|
| 32 | | | | | | | | | | | | | |
|----|--|--|--|--|--|--|--|--|--|--|--|--|--|

Ⓢ HDG Ⓢ SS Ⓢ BRASS

* Also available in stainless -steel

Ⓢ Non Suitable

Ⓢ Suitable

Ⓢ Suitable with care



CAN BOLT CAN SHELL

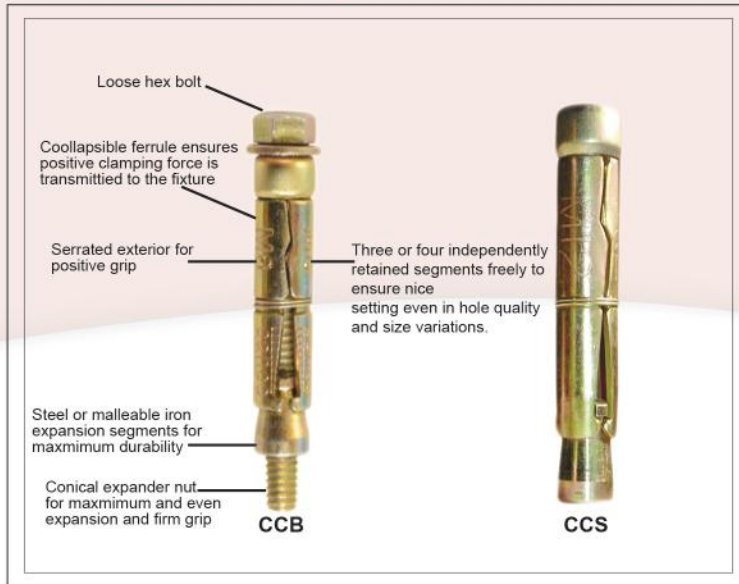

ADVANTAGES

- Installing heavy equipment and machinery.
- Fixing balustrade, barriers, roller shutter doors, fire doors and switchgear.
- Securing structural fixtures.
- Optimum taper nut angle for maximum expansion in all substrates.
- Shield available seperately.

APPLICATIONS

- For use in concrete and most types masonry.
- Ideal for overhead and ceiling work or heavy items.
- Securing cable trays. Ducting and trunking.
- Installing partitions and structural fixtures.
- For use in Roller shutter doors.
- For use in Fire doors.
- For use in Steelwork.

PRODUCT SPECIFICATION

| Bolt Size | Bolt Length | Fixture Thickness | Hole Diameter | Minimum Hole Depth | Packing |
|-----------|-------------|-------------------|---------------|--------------------|---------|
| | [mm] | [mm] | [mm] | [mm] | pcs |
| M6 | 55 | 10 | 12 | 50 | 50 |
| | 70 | 25 | | | |
| | 85 | 40 | | | |
| M8 | 65 | 10 | 14 | 55 | 50 |
| | 80 | 25 | | | |
| | 95 | 40 | | | |
| M10 | 75 | 10 | 16 | 65 | 50 |
| | 90 | 25 | | | |
| | 115 | 50 | | | |
| | 140 | 75 | | | |
| M12 | 90 | 15 | 20 | 85 | 25 |
| | 105 | 25 | | | |
| | 120 | 40 | | | |
| | 140 | 60 | | | |
| M16 | 135 | 15 | 25 | 125 | 10 |
| | 150 | 30 | | | |
| | 180 | 60 | | | |
| M20 | 195 | 60 | 32 | 140 | 10 |
| | 235 | 100 | | | |
| M24 | 255 | 100 | 38 | 160 | 5 |
| | 300 | 150 | | | 2 |

* If the fixture thickness is less than the stated maximum, increase hole depth by the difference between actual and maximum thickness.





CAN PROJECTION ANCHOR

ADVANTAGES

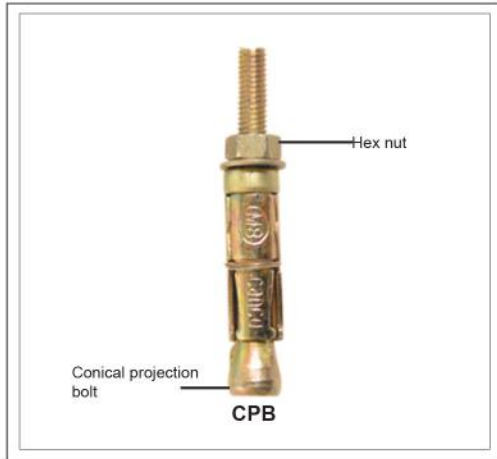

- Provides a projecting stud to support fixture during installation and removal.
- ferrule marked with hole diameter for correct installation.
- Pressed steel segments ensure consistent dimensional accuracy.
- Optimum taper nut angle for maximum expansion in all substrates.

APPLICATIONS

- Roller shutter doors.
- Fire doors.
- Wall plates.
- Security grills.
- Signs.
- Fencing.

PRODUCT SPECIFICATION

| Bolt Size | Bolt Length | Fixture Thickness | Hole Diameter | Minimum Hole Depth | Packing |
|-----------|-------------|-------------------|---------------|--------------------|---------|
| | [mm] | | | | |
| M6 | 65 | 10 | 12 | 50 | 50 |
| | 80 | 25 | | | |
| | 115 | 60 | | | |
| M8 | 75 | 10 | 14 | 55 | 50 |
| | 90 | 25 | | | |
| | 125 | 60 | | | |
| M10 | 90 | 15 | 16 | 65 | 50 |
| | 105 | 30 | | | |
| | 135 | 60 | | | |
| M12 | 110 | 15 | 20 | 85 | 25 |
| | 125 | 30 | | | |
| | 170 | 75 | | | |
| M16 | 150 | 15 | 25 | 125 | 10 |
| | 170 | 35 | | | |
| | 210 | 75 | | | |
| M20 | 170 | 15 | 32 | 140 | 10 |
| | 185 | 30 | | | |
| | 255 | 100 | | | |
| M24 | 255 | 75 | 38 | 160 | 5 |
| | 300 | 150 | | | 2 |

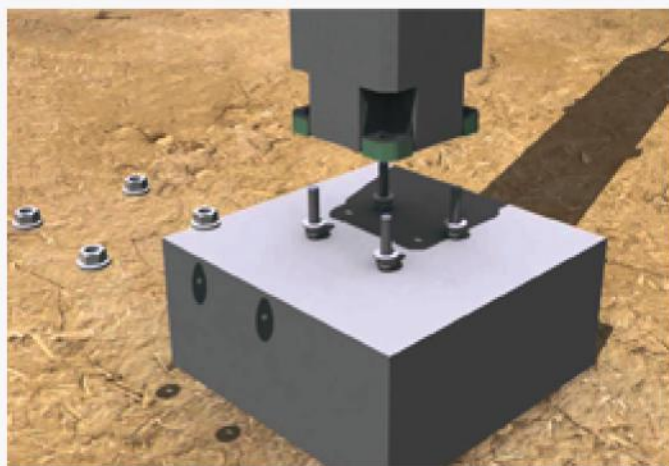



CAN EYE CAN HOOK BOLT



ADVANTAGES

- Suitable for permanent anchorage.
- Securing guy ropes, stays and cables.
- Supply complete with shield washer & hex nut.
- Optimum geometry taper angle for maximum expansion in all substrates.
- Hook and forged eye designed & manufactured for maximum performance.

APPLICATIONS

- Suitable for use as a secure anchor for hanging.
- Supporting non-safety related cables.
- Supporting lighting fixtures and equipment.
- Providing secure anchorage for chain barriers.
- Supporting ladder restints

PRODUCT SPECIFICATION

| Bolt Size | Bolt Length | Fixture Thickness | Hole Diameter | Hook/Eye diameter | Packing pcs. |
|-----------|-------------|-------------------|---------------|-------------------|--------------|
| | [mm] | | | | |
| M6 | 73 | 12 | 50 | 10 | 25 |
| | 83 | | | 8 | |
| M8 | 87 | 14 | 55 | 12 | |
| | 98 | | | 10 | |
| M10 | 108 | 16 | 65 | 14 | |
| | 120 | | | 12 | |
| M12 | 130 | 20 | 85 | 17 | |
| | 145 | | | 16 | |
| M16 | 150 | 25 | 110 | 22 | |
| | 175 | | | 20 | |



INSTALLATION INSTRUCTIONS

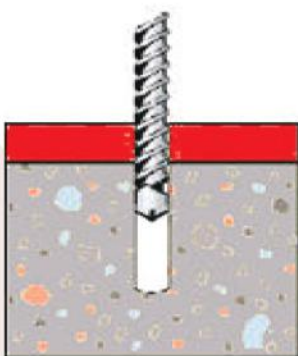

Drill hole to correct diameter and recommended depth.

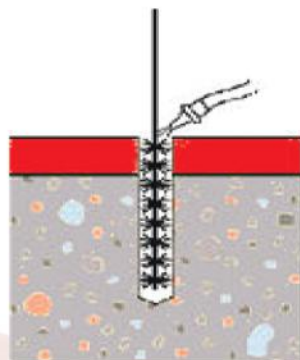

Remove debris and clean hole thoroughly.

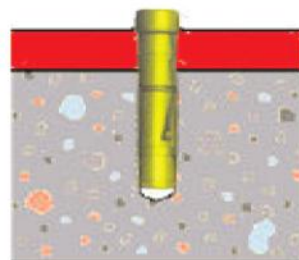

Remove bolt and washer, insert the shield in to the hole.

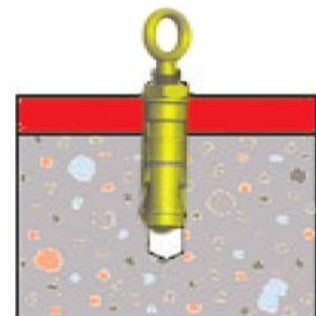

Insert bolt through washer and fixture, replace bolt in to shield and tighten to the recommended torque.



CHEMICAL CAPSULE

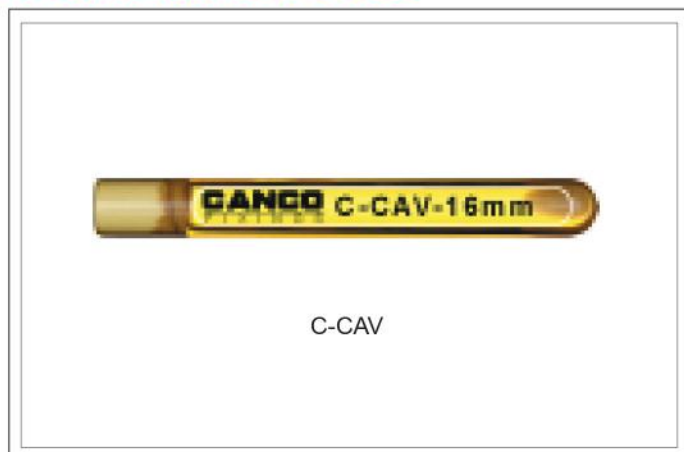

ADVANTAGES

- High performance .
- Quick and easy to install.
- Capsule contains exact amounts of ingredients making it a very consistent product (no waste).
- Adhesive strength is not affected by unpolluted water (curing time will be affected).

APPLICATIONS

- Heavy machinery.
- Stuructral steel.

PRODUCT SPECIFICATION

| Hole Diameter [mm] | Minimum Hole Depth [mm] | L _c [mm] | Packing pcs |
|-----------------------|----------------------------|------------------------|----------------|
| 10 | M8 | 85 | 10 |
| 12 | M10 | 85 | 10 |
| 14 | M12 | 95 | 10 |
| 18 | M16 | 95 | 10 |
| 25 | M20 | 180 | 6 |
| 28 | M24 | 215 | 6 |
| 35 | M30 | 270 | 2 |

CHEMICAL STUDS



C-STUDS HEXAGONAL HEAD STUDS - ZINC PLATED

| Bolt Size | Packing |
|-----------|---------|
| M8x110 | 10 |
| M8x160 | 10 |
| M10x130 | 10 |
| M10x170 | 10 |
| M10x190 | 10 |
| M12x160 | 10 |
| M12x190 | 10 |
| M12x220 | 10 |
| M12x260 | 10 |
| M12x300 | 5 |
| M16x190 | 10 |
| M16x260 | 10 |
| M16x300 | 5 |
| M16x380 | 1 |
| M20x260 | 5 |
| M20x300 | 1 |
| M20x350 | 1 |
| M20x300 | 1 |
| M20x380 | 1 |





CAN THROUGH BOLT

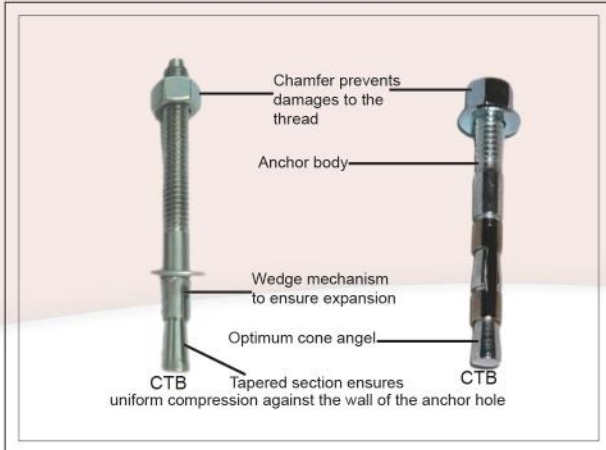

ADVANTAGES

- Easy installation into the base material through the fixture and series installation.
- Used when marking out, hole spotting is difficult.
- Ensures large time saving as a result of smaller drill hole.
- Can be used in tension zone.

APPLICATIONS

- Installing heavy machinery & other fixtures when it is difficult to mark out the hole.
- Fixing of protective railings.
- Fixing console, traverses and ducts.
- Fixing cable lines & safety equipments.
- Steel to concrete: Columns, racking, safety barriers, hand rails and stair ways.

PERFORMANCE SHEET OF SINGLE EXPANDER THROUGH BOLT

| Bolt Size | Bolt Length | Fixture Thickness | Packing | Packing |
|-----------|-------------|-------------------|---------|---------|
| | [mm] | [mm] | pcs. | pcs. |
| M6 | 40 | 2 | 100 | 2400 |
| | 55 | 15 | 100 | 2400 |
| | 85 | 45 | 100 | 1200 |
| M8 | 50 | 3 | 100 | 1200 |
| | 75 | 20 | 100 | 1200 |
| | 95 | 40 | 100 | 1200 |
| | 115 | 60 | 100 | 1200 |
| M10 | 60 | 3 | 50 | 600 |
| | 80 | 20 | 50 | 600 |
| | 100 | 40 | 50 | 600 |
| | 120 | 60 | 50 | 600 |
| M12 | 70 | 5 | 50 | 600 |
| | 100 | 20 | 25 | 300 |
| | 130 | 50 | 25 | 300 |
| | 180 | 100 | 25 | 200 |
| M16 | 100 | 20 | 25 | 200 |
| | 120 | 40 | 25 | 200 |
| | 180 | 100 | 10 | 80 |
| | 200 | 120 | 10 | 80 |
| M20 | 160 | 45 | 10 | 80 |
| | 200 | 85 | 10 | 80 |
| | 250 | 135 | 10 | 50 |





CAN SAFETY ANCHORS

ADVANTAGES

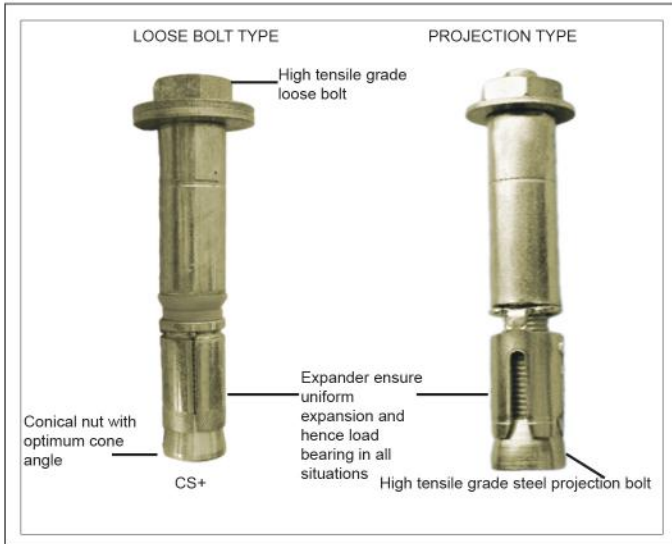

- Quick and series installations.
- Used where strict tolerances have specified.
- **Maximum reliability:-**
 - (a) Even in cracked concrete zone.
 - (b) Even at shallow embedment depth.
- Useful where aesthetics and safety both are required.
- Fixing through the fixture is possible.
- Fixing in the tensile zone of high strength & reinforced concrete.

APPLICATIONS

- Fixing of suspension stems for heavy pipe installations.
- Fixing channels, girders etc.
- Primary construction fixings.
- Production machinery fixing.
- Construction props.
- Lift guide rails.
- Building facades.

SPECIFICATION AND PERFORMANCE SHEET

| Bolt Size | Bolt Length | Fixture Thickness | Hole Diameter | Minimum Hole Depth | Packing |
|-----------|-------------|-------------------|---------------|--------------------|---------|
| | [mm] | [mm] | [mm] | [mm] | pcs. |
| M8 | 90 | 15 | 12 | 80 | 50 |
| | 90 | 20 | | | |
| | 95 | 15 | | | |
| | 110 | 40 | | | |
| M10 | 105 | 20 | 15 | 90 | 50 |
| | 105 | 25 | | | |
| | 110 | 20 | | | |
| | 120 | 40 | | | |
| | 140 | 60 | | | |
| M12 | 120 | 25 | 18 | 110 | 25 |
| | 125 | 30 | | | |
| | 135 | 25 | | | |
| | 150 | 50 | | | |
| | 160 | 50 | | | |
| M16 | 145 | 25 | 24 | 125 | 10 |
| | 145 | 30 | | | |
| | 160 | 25 | | | |
| | 170 | 50 | | | |
| | 185 | 50 | | | |
| M20 | 175 | 30 | 28 | 155 | 10 |
| | 190 | 30 | | | |

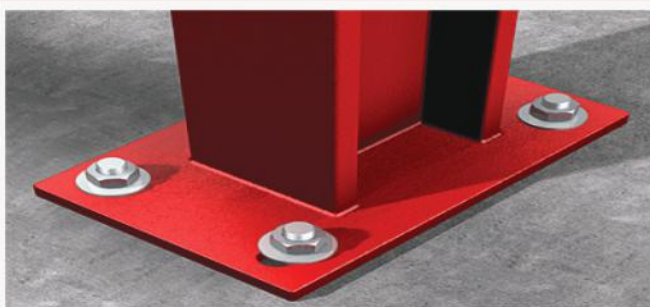



CAN SLEEVE ANCHOR

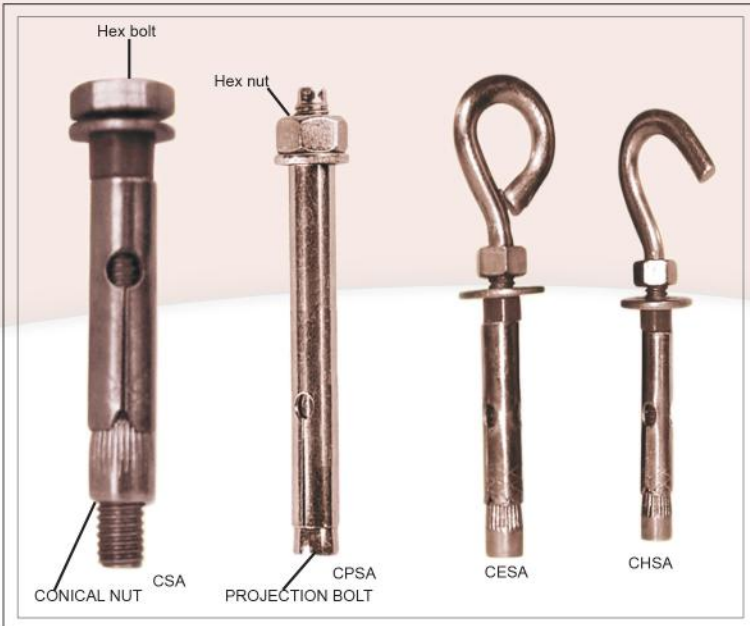

ADVANTAGES

- When hole marking spotting is difficult.
- Available in double sleeve and SS.
- Fully assembled.
- Unique sleeve design to provide pull down onto fixture.
- Carbon steel, zinc -plate.
- Through fixture installation.
- Wide rage of anchor lengths.

APPLICATIONS

- limber to concrete : Form work, battens and bottom plates.
- Services : Duct work, Pipes brackets, cable trays.Fully assembled.
- Suspended ceilings.
- Metal work : Signs, hand rails and gates.
- For fitting Stadium seating.
- Fixing Satellite dishes
- For fitting shutters.

PRODUCT SPECIFICATION

| Bolt Size | Bolt Length | Fixture Thickness | Packing | Packing |
|-----------|-------------|-------------------|---------|---------|
| | [mm] | [mm] | pcs. | pcs. |
| M6 | 40 | 2 | 100 | 1200 |
| | 65 | 25 | 100 | 1200 |
| | 85 | 45 | 100 | 1200 |
| M8 | 40 | 3 | 100 | 1200 |
| | 50 | 3 | 100 | 1200 |
| | 60 | 10 | 50 | 600 |
| | 80 | 30 | 50 | 600 |
| M10 | 100 | 50 | 50 | 600 |
| | 60 | 3 | 50 | 600 |
| | 75 | 15 | 50 | 600 |
| M12 | 100 | 40 | 50 | 600 |
| | 130 | 70 | 25 | 30 |
| | 110 | 50 | 25 | 300 |
| M16 | 150 | 90 | 20 | 160 |
| | 105 | 35 | 20 | 160 |
| | 110 | 40 | 10 | 80 |
| | 130 | 60 | 10 | 80 |
| | 150 | 80 | 10 | 80 |

* If the edge distance and spacings are less than the standard value the standard values, reduce the loads by factors given in section B.

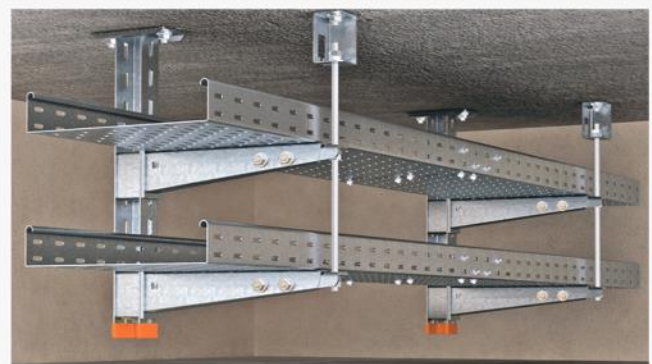



CAN HAMMER DRIVER ANCHOR



ADVANTAGES

- Deformation controlled anchor with less displacement (Load - displacement curve similar to adhesive type anchors).
- Easy installations.
- Through fixing and series installation.
- Yellow passivated or sheradised to ensure optimum protection against corrosion.
- Also available in stainless-steel.

APPLICATIONS

- Timber to concrete: Form work, battens and bottom plates.
- Services: Duct work, Pipes brackets, cable trays.
- Metal work: Signs, hand rails and gates.

PRODUCT SPECIFICATION

| Ref. | Anchor size (mm) | Anchor length (mm) | Drill dia (mm) | Holding Power (mm) | Packing |
|------|------------------|---------------------------------------|----------------------------------|--------------------------------------|---------|
| CZA | M6 | 40 50 | 6 6 | 0.50 0.75 | 200 |
| CZA | M8 | 40 50 60 75 100 | 8 8 8 8 8 | 0.75 1.00 1.50 1.75 2.00 | 1000 |
| CZA | M10 | 50 75 100 125 | 10 10 10 10 | 1.50 1.75 2.00 2.50 | 50 |
| CZA | M12 | 60 75 100 150 | 12 12 12 12 | 2.50 2.75 3.00 3.50 | 50 |
| CZA | M14 | 100 125 150 | 14 14 14 | 3.00 3.50 3.75 | 25 |
| CZA | M16 | 75 100 125 150 175 200 | 16 16 16 16 16 16 | 3.50 3.70 4.00 4.50 4.75 | 20 |
| CZA | M20 | 150 200 | 20 20 | 5.00 6.00 | 10 |
| CZA | M22 | 160 | 22 | 7.00 | 10 |
| CZA | M24 | 175 200 | 24 24 | 8.00 8.50 | 10 |



CAN DROP IN ANCHOR



ADVANTAGES

- Available in Carbon steel & Stainless steel.
- Maximum expansion against the wall of the hole.
- Shell is forced outward in four directions compressing against the walls of the hole.
- Developed compression force is usually very high when compared to torque controlled anchors, hence low displacement.
- Larger bearing area.
- Fixes equipments that may require to be removed and replaced.
- Flush fitting - no protrusions when not in use.

APPLICATIONS

- For fixing light weight equipment to ceilings and walls using threaded rods.
- Attaching pipe works to ceilings and walls.
- Fixing wire-mesh for debris control.
- Racking.
- Suspended services in stadium seating.

PRODUCT SPECIFICATION & PERFORMANCE SHEET

| Bolt Size | Bolt Length | Packing | |
|-----------|-------------|---------|------|
| | [mm] | pcs. | pcs. |
| M6 | 30 | 100 | 1500 |
| M8 | 30 | 100 | 1000 |
| M10 | 40 | 100 | 500 |
| M12 | 50 | 50 | 250 |
| M16 | 65 | 50 | 100 |
| M20 | 80 | 50 | 100 |



INSTALLATION INSTRUCTIONS

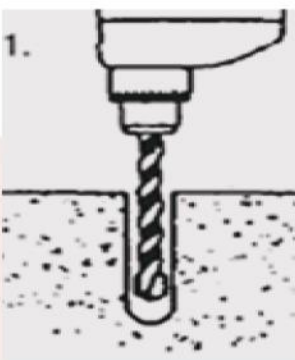

1. Drill Hole (Same drill depth as anchor length.)

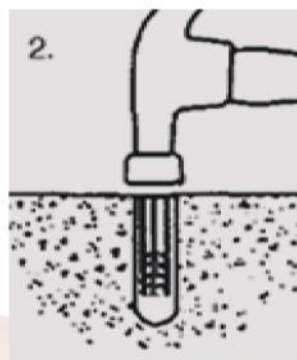

2. Insert anchor.

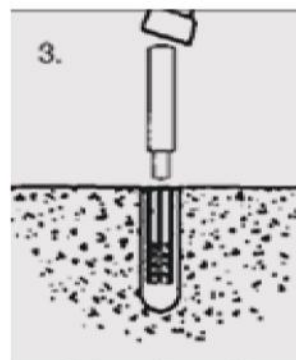

3. Set anchor with setting tool.

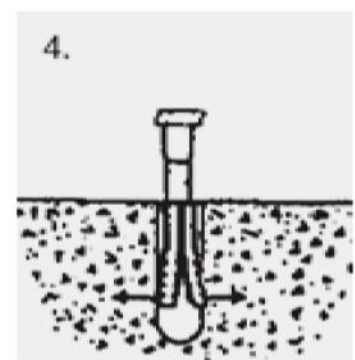

4. Drop-In Anchor is set and ready to accept any length bolt or threaded rod.



CAN FRAME FIXING

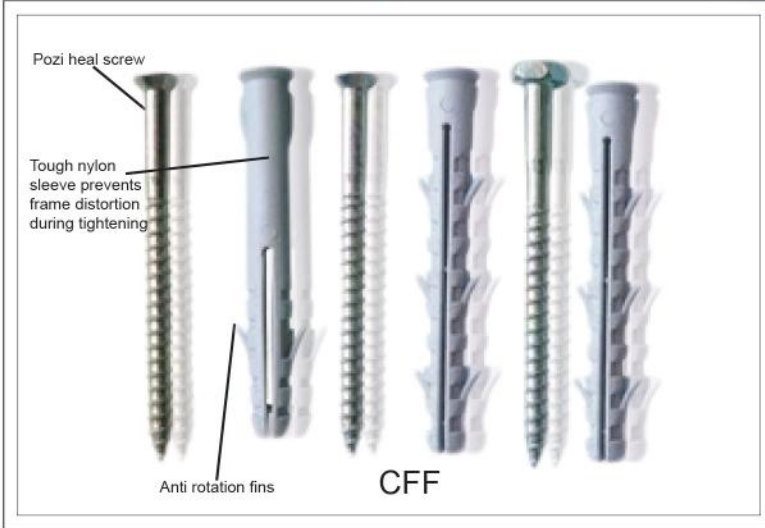

ADVANTAGES

- Through fixing installations.
- Spacing installations
- Quick & easy fixing.
- Durable PA6 grade nylon for extended fixing life.
- Tough nylon sleeve prevents frame distortion during tightening.

APPLICATIONS

- For through fixing and spacing installations in interior construction work.
- Also in some external cladding work.
- For fixing timber or metal window and le fixing. door frames to concrete, stone, brick or block work.
- No marking out -drill straight through frame.

PRODUCT SPECIFICATION & PERFORMANCE SHEET

| Dimension | Screw head Type [mm] | Hole Diameter [mm] | Max Fixture Thickness [mm] | Quantity | Packing |
|-----------|----------------------|--------------------|----------------------------|----------|---------|
| 8 x 60 | Countersunk Pozi 3 | 8 | 20 | 16 | 50 |
| | | | | 50 | |
| 8 x 80 | Countersunk Pozi 3 | 8 | 40 | 4 | 50 |
| | | | | 6+drill | |
| | | | | 16 | |
| | | | | 50 | |
| 8 x 100 | Countersunk Pozi 3 | 8 | 60 | 16 | 50 |
| | | | | 50 | |
| 8 x 120 | Countersunk Pozi 3 | 8 | 80 | 16 | 50 |
| | | | | 50 | |
| 10 x 80 | Countersunk Pozi 4 | 10 | 30 | 12 | 25 |
| | | | | 50 | |
| 10 x 100 | Countersunk Pozi 4 | 10 | 50 | 4 | 25 |
| | | | | 6+ drill | |
| | | | | 12 | |
| | | | | 50 | |
| 10 x 120 | Countersunk Pozi 4 | 10 | 70 | 4 | 25 |
| | | | | 12 | |
| | | | | 16 | |
| | | | | 50 | |
| 10 x 135 | Countersunk Pozi 4 | 10 | 85 | 4 | 25 |
| | | | | 12 | |
| | | | | 50 | |
| 10 x 160 | Countersunk Pozi 4 | 10 | 110 | 12 | 25 |
| | | | | 50 | |





CAN BRASS ANCHOR



ADVANTAGES

- Larger bearing area.
- Acts as a socket.
- Fixture can be removed and replaced.
- Suitable for solid brick, light concrete hollow core concrete panels and timber.
- Internal tapering to enable the anchor to expand and to self lock the suspension rod into position.
- The body is knurled for improved performance.

APPLICATIONS

- Can be used in scaffolding, painting, ventilating etc.

| Thread Size [mm] | Hole Diameter [mm] | Hole Depth [mm] | Anchor Length [mm] | Quantity | |
|------------------|--------------------|-----------------|--------------------|----------|-------|
| | | | | Packing | Outer |
| M5 | 7 | 22 | 20 | 100 | 2400 |
| M6 | 8 | 24 | 22 | 100 | 2400 |
| M8 | 10 | 32 | 32 | 100 | 2400 |
| M10 | 12 | 34 | 32 | 100 | 2400 |
| M12 | 15 | 40 | 38 | 50 | 1200 |
| M16 | 20 | 48 | 45 | 50 | 1200 |

CAN NAIL PLUG

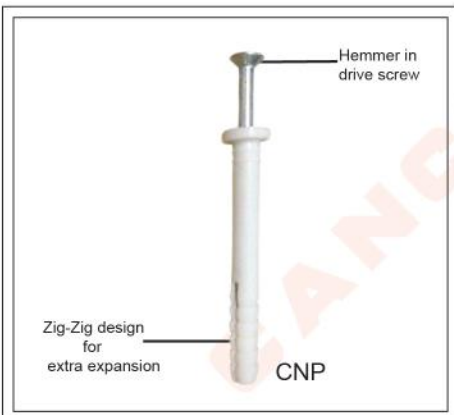

ADVANTAGES

- Fast fixing with minimal screw driver work.
- Available loose or pre assembled.
- Deforming crumple zone allows quick adjustment in uneven surfaces.
- Extended expansion zone gives extra grip.

APPLICATIONS

- Fixing stud bottoms to walls before cladding.
- Fixing long runs of shelf support.
- Fixing skirting boards to walls.

| Plug Description | Hole Diameter | Screwhead Type | Quantity | |
|------------------|---------------|----------------|----------|-------|
| | | | Packing | Outer |
| 8 x 100 | 8 | POZI2 | 50 | 600 |
| 8 x 120 | 8 | POZI2 | 50 | 600 |
| 8 x 140 | 8 | POZI2 | 50 | 600 |





CAN SPRING TOGGLE



ADVANTAGES

- Spreads load over wide area for extra security.
- Most suitable for overhead fixings in plasterboard or lath and plaster.
- No special tools required.
- Machine screw for ease of tightening .
- Heavy guage material for superior loads.

APPLICATIONS

- Installing overhead lights and other fixings.
- Securing timber to 'plasterboard walls.
- Installing cavity walls and ceiling of low structural strength.

| Description | Hole Diameter [mm] | Max Fixture Thickness [mm] | Product Radius [mm] | Options | Quantity | Packing |
|-------------|--------------------|----------------------------|---------------------|-------------|----------|---------|
| M3 x 50 | 11 | 30 | 20 | With screws | 6 | 1000 |
| M3 x 50 | 11 | 30 | | With screws | 10 | |
| M3 x 50 | 11 | 30 | | With screws | 20 | |
| M3 x 50 | 11 | 30 | | With screws | 100 | |
| M3 | 11 | N/A | | No screws | 100 | |
| M5 x 50 | 14 | 24 | 25 | With screws | 6 | 500 |
| M5 x 50 | 14 | 24 | | With screws | 20 | |
| M5 x 80 | 14 | 54 | 25 | With screws | 6 | 500 |
| M5 x 80 | 14 | 54 | | With screws | 10 | |
| M5 x 80 | 14 | 54 | | With screws | 20 | |
| M5 x 80 | 14 | 54 | | With screws | 100 | |
| M5 | 14 | N/A | | No screws | 100 | |
| M6 x 80 | 18 | 48 | | With screws | 50 | 500 |
| M6 | 18 | N/A | | With screws | 50 | |

CAN PLASTIC PLUG

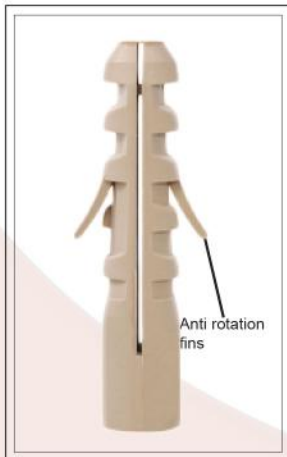

ADVANTAGES

Cost effective fixings for lightweight applications in sound brick, blockwork or concrete.

- All purpose fixing for lightweight applications in brick, blockwork or concrete.
- Fixing central heating pipes, shelving, brackets, dado rails and other woodwork.
- Securing light wall units and kitchen fittings.

APPLICATIONS

- Shelving and cabinets.
- Suspended ceilings.
- Switch and cable trays.
- Boilers.
- Water heaters & radiators.

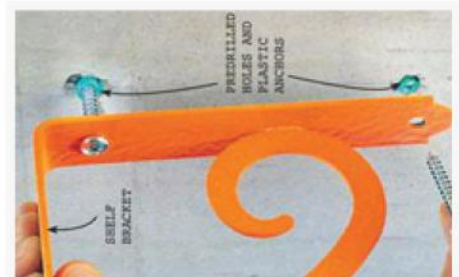

| Hole Diameter [mm] | Plug Length [mm] | Screw Dimensions [mm] | Packing Quantity [mm] | Outer Quantity |
|--------------------|------------------|-----------------------|-----------------------|----------------|
| 6 | 40 | 4.0 x 40 | 200 | 2400 |
| 6 | 40 | 4.0 x 50 | 200 | 2400 |
| 6 | 40 | 4.0 x 60 | 200 | 2400 |
| 8 | 50 | 4.5 x 50 | 100 | 1200 |
| 8 | 50 | 4.5 x 60 | 100 | 1200 |
| 8 | 50 | 4.5 x 70 | 100 | 1200 |
| 10 | 60 | 5.0 x 60 | 50 | 600 |
| 10 | 60 | 5.0 x 70 | 50 | 600 |
| 10 | 60 | 5.0 x 80 | 50 | 600 |
| 10 | 60 | 5.0 x 100 | 20 | 300 |



CAN HIT PIN CHP



ADVANTAGES

- Fast fixing with minimal screw driver work.
- Available loose or pre assembled.

APPLICATIONS

- Fixing stud bottoms to walls before cladding. Available loose or pre assembled.
- Fixing long runs of shelf support.
- Fixing skirting boards to walls.



| Plug Description | Hole Diameter [mm] | Flange Diameter [mm] | Quantity | |
|------------------|--------------------|----------------------|----------|-------|
| | | | Packing | Outer |
| 5 x 20 | 5 | 12 | 100 | 3600 |
| 6 x 30 | 6 | 12 | 100 | 1800 |
| 6 x 40 | 6 | 12 | 100 | 1200 |
| 6 x 50 | 6 | 12 | 100 | 1200 |
| 6 x 65 | 6 | 12 | 100 | 1200 |

CAN CEILING ANCHOR



ADVANTAGES

- Mainly for fixing lightweight ceilings and suspended ceilings to solid building materials. Fire resistant

APPLICATIONS

- Lightweight suspended ceilings

| Plug Description | Hole Diameter (mm) (d ₀) | Pc/ Box |
|------------------|--------------------------------------|---------|
| 6x40 | 6 | 100 |
| 6x65 | 6 | 100 |

CEILING WIRE HANGER



ADVANTAGES

- Mainly for fixing lightweight ceilings and suspended ceilings to solid building materials. Fire resistant

APPLICATIONS

- Lightweight suspended ceilings

| Dimension | Hole Diameter (mm) (d ₀) | Quantity | |
|-----------|--------------------------------------|----------|-------|
| | | Pack | outer |
| 6x63 | 6 | 100 | 2400 |



SELF DRILLING SCREWS (DRILLING CAPACITY 12MM)

ADVANTAGES



SCREW:-

- surface hardened carbon steel- zinc electroplated 16f.
- Hexagonal flange head.
- Special head design with collar of ONP screw guarantee even installation and tightness of the connection.
- Available with or without EPDM washer

APPLICATIONS

- Fixing of sheet metal to steel structures on facades or flat roof construction .
- Fixings elements of steel construction.

| Screw size DxL(mm) | Max Drilling Thick- ness (mm) | Head Size (mm) | Max Fixture Thickness | |
|-----------------------|-------------------------------------|-------------------|-----------------------|--|
| | | | Screw With Washer | Screw Without Washer t_{fix} (mm) |
| 5.5x32 | 12.0 | 8.0 | 12.0 | 15.0 |
| 5.5x38 | | | 17.0 | 20.0 |
| 5.5x32 | | | 12.0 | 15.0 |
| 5.5x38 | | | 17.0 | 20.0 |

SELF DRILLING SCREWS (DRILLING CAPACITY 3,5,6,8MM)

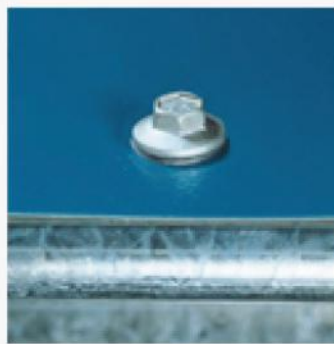

ADVANTAGES

- Fixing of sheet metal to steel structures on facades or flat roof construction
- Under head non threaded zone eliminates thread breakage in sheet metal hexagonal flange head.
- Special head design together with washer guarantee even installation and tightness of the connection.
- Available with or without EPDM washer.

APPLICATIONS

SCREW:-

- surface hardened carbon steel- zinc electroplated 16f WASHER FOR SCREWS 4.8.

| Screw Size DxL [mm] | Max Drilling Thickness | | Max Fixture Thickness | | Packing |
|------------------------|------------------------|------|-----------------------|-----------------------|---------|
| | | | Screw with washer | Screw with out washer | |
| | [mm] | [mm] | t_{fix} [mm] | | |
| 4.8x16 | 3.0 | 8 | 4.0 | 7.0 | 250 |
| 4.8x18 | | | 7.0 | 10.0 | 250 |
| 4.8x22 | | | 10.0 | 13.0 | 250 |
| 4.8x25 | | | 13.0 | 16.0 | 250 |
| 4.8x32 | | | 20.0 | 23.0 | 250 |
| 4.8x35 | | | 23.0 | 26.0 | 250 |
| 4.8x38 | | | 26.0 | 29.0 | 250 |
| 4.8x45 | | | 33.0 | 39.0 | 100 |
| 4.8x55 | | | 42.0 | 45.0 | 100 |
| 5.5x22 | | | 5.0 | 8 | 9.0 |
| 5.5x25 | 12.0 | 15.0 | | | 200 |
| 5.5x32 | 19.0 | 22.0 | | | 100 |
| 5.5x38 | 25.0 | 28.0 | | | 100 |
| 5.5x45 | 31.0 | 34.0 | | | 100 |
| 5.5x55 | 35.0 | 38.0 | | | 100 |



| | | | | | |
|--------|-----|----|-------|-------|-----|
| 5.5x75 | 8.0 | 8 | 55.0 | 58.0 | 100 |
| 5.5x90 | | | 70.0 | 73.0 | 100 |
| 5.5x12 | | | 100.0 | 103.0 | 100 |
| 6.3x19 | 6.0 | 10 | 6.0 | 9.0 | 100 |
| 6.3x22 | | | 9.0 | 12.0 | 100 |
| 6.3x25 | | | 12.0 | 15.0 | 100 |
| 6.3x32 | | | 19.0 | 22.0 | 100 |
| 6.3x38 | | | 25.0 | 28.0 | 100 |
| 6.3x45 | | | 31.0 | 34.0 | 100 |
| 6.3x55 | | | 35.0 | 38.0 | 100 |
| 6.3x75 | | | 55.0 | 58.0 | 100 |
| 6.3x90 | | | 70.0 | 73.0 | 100 |
| 6.3x12 | | | 100.0 | 103.0 | 100 |

CAN DRILL SCREW



ADVANTAGES

- No drill required.
- Can be used in double thickness plasterboard, aerated concrete, gypsum and chipboard.
- Sharp plug point ensures a careful pre drilling.

APPLICATIONS

- Securing small cabinets, mirrors or picture frames.
- Fixing wall and ceiling light fittings, securing hooks, brackets and other fittings.

| Description | Full Length [mm] | Dia.[mm] | Packing |
|---------------|------------------|----------|---------|
| No.10-16x20mm | 20mm | 4.8 | 250 |
| No.10-16x25mm | 25mm | 4.8 | 250 |
| No.12-14x25mm | 25mm | 5.5 | 100 |
| No.12-14x35mm | 35mm | 5.5 | 100 |
| No.12-14x45mm | 45mm | 5.5 | 100 |
| No.12-14x55mm | 55mm | 5.5 | 100 |
| No.12-14x68mm | 68mm | 5.5 | 100 |
| No.14-16x25mm | 25mm | 6.3 | 100 |
| No.14-16x50mm | 50mm | 6.3 | 100 |

SELF DRILLING SCREWS (DRILLING CAPACITY 2.5MM)



ADVANTAGES

- Made according to DIN 7504 K,
- Reduced drilling point guaranteeing quick and firm installation in wooden substrate,
- Available with EPDM washer
- For fixing profiled sheet to wood.

APPLICATIONS

SCREW:-

- surface hardened carbon steel- zinc electroplated 16f.

| Screw size DxL(mm) | Max Drilling Thickness (mm) | Head Size (mm) | Max Fixture Thickness | | Packing |
|-----------------------|--------------------------------|-------------------|-----------------------|--|---------|
| | | | Screw With Washer | Screw Without Washer t_{fix} (mm) | |
| 4.8x28 | 2.5 | 8 | 5.0 | 8.0 | 250 |
| 4.8x35 | | | 12.0 | 15.0 | 250 |
| 4.8x55 | | | 32.0 | 35.0 | 250 |



SELF DRILLING SCREWS (DRILLING CAPACITY 2.5 MM)



ADVANTAGES

- Overlapping sheet connection.
- Made according to DIN 7504 K.
- Reduced drilling point guarantees optimum tightness of the fastening.
- Full thread eliminates overtightening of the screw, allows the screw to be used without a washer if waterproof connection is not needed.
- Available with or without EPDM washer

APPLICATIONS

SCREW:-

- surface hardened carbon steel- zinc electroplated 16f.

| Screw size DxL(mm) | Max Drilling Thickness (mm) | Head Size (mm) | Max Fixture Thickness | | Packing |
|-----------------------|--------------------------------|-------------------|---|-------|---------|
| | | | Screw With Washer Without Washer t_{fix} (mm) | Screw | |
| 4.8X16 | 2.5 | 8 | 4.0 | 7.0 | 250 |
| 4.8X19 | 2.5 | | 7.0 | 10.0 | 250 |

DRY WALL SCREWS



ADVANTAGES

- Low-carbon steel-black phosphate coating to resist corrosion.

APPLICATIONS

- Mainly in drywall systems for fixing plasterboards to wooden framing.

| Screw Size (mm) | Scerthead Type | Box/Pack Quantity(pcs) |
|-----------------|----------------|------------------------|
| 3.5x25 | PHILIPS2 | 1000 |
| 3.5x32 | PHILIPS2 | 1000 |
| 3.5x35 | PHILIPS2 | 1000 |
| 3.5x38 | PHILIPS2 | 1000 |
| 3.5x42 | PHILIPS2 | 500 |
| 3.5x45 | PHILIPS2 | 500 |
| 3.5x50 | PHILIPS2 | 500 |
| 3.5x55 | PHILIPS2 | 500 |
| 3.5x60 | PHILIPS2 | 250 |
| 3.5x70 | PHILIPS2 | 250 |
| 3.5x75 | PHILIPS2 | 250 |
| 3.5x90 | PHILIPS2 | 250 |
| 3.5x100 | PHILIPS2 | 200 |
| 3.5x110 | PHILIPS2 | 200 |
| 3.5x120 | PHILIPS2 | 200 |



CHIPBOARD SCREWS

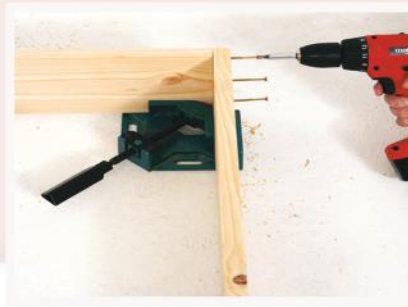

ADVANTAGES

- Low carbon steel, electro zinc plated min.6f protection against chemical present in treated pine.

APPLICATIONS

- For screwing into chipboard, timber, plastics with no pre-drilling

Size (All Dimension in MM dxL)

| Screw Size | Screw Head | Description | Quantity | |
|------------|------------|-------------|----------|-------|
| | | | Box | Outer |
| 2.5x10 | Pozidrive1 | Full Thread | 200 | 9600 |
| 2.5x12 | Pozidrive1 | Full Thread | 200 | 9600 |
| 2.5x16 | Pozidrive1 | Full Thread | 200 | 9600 |
| 3.0x12 | Pozidrive1 | Full Thread | 200 | 9600 |
| 3.0x16 | Pozidrive1 | Full Thread | 200 | 9600 |
| 3.0x18 | Pozidrive1 | Full Thread | 200 | 9600 |
| 3.0x20 | Pozidrive1 | Full Thread | 200 | 9600 |
| 3.0x25 | Pozidrive1 | Full Thread | 200 | 9600 |
| 3.0x30 | Pozidrive1 | Full Thread | 200 | 4800 |
| 3.0x35 | Pozidrive1 | Full Thread | 200 | 9600 |
| 3.0x40 | Pozidrive1 | Full Thread | 200 | 9600 |
| 3.5x12 | Pozidrive1 | Full Thread | 200 | 9600 |
| 3.5x16 | Pozidrive1 | Full Thread | 200 | 9600 |
| 3.5x18 | Pozidrive1 | Full Thread | 200 | 9600 |
| 3.5x20 | Pozidrive1 | Full Thread | 200 | 9600 |
| 3.5x25 | Pozidrive1 | Full Thread | 200 | 9600 |
| 3.5x30 | Pozidrive1 | Full Thread | 200 | 9600 |
| 3.5x35 | Pozidrive1 | Full Thread | 200 | 4800 |
| 3.5x40 | Pozidrive1 | Full Thread | 200 | 4800 |
| 3.5x45 | Pozidrive1 | Full Thread | 200 | 4800 |
| 4.0x16 | Pozidrive1 | Full Thread | 200 | 9600 |
| 4.0x18 | Pozidrive1 | Full Thread | 200 | 9600 |
| 4.0x20 | Pozidrive1 | Full Thread | 200 | 9600 |
| 4.0x25 | Pozidrive1 | Full Thread | 200 | 9600 |
| 4.0x30 | Pozidrive1 | Full Thread | 200 | 4800 |
| 4.0x35 | Pozidrive1 | Full Thread | 200 | 4800 |
| 4.0x40 | Pozidrive1 | Full Thread | 200 | 4800 |
| 4.0x45 | Pozidrive1 | Full Thread | 200 | 4800 |
| 4.0x50 | Pozidrive1 | Full Thread | 200 | 4800 |
| 4.0x55 | Pozidrive1 | Full Thread | 200 | 4800 |
| 4.0x60 | Pozidrive1 | Full Thread | 200 | 4800 |
| 4.0x70 | Pozidrive1 | Full Thread | 200 | 9600 |
| 4.0x80 | Pozidrive1 | Full Thread | 200 | 2400 |
| 4.5x16 | Pozidrive1 | Full Thread | 200 | 9600 |
| 4.5x20 | Pozidrive1 | Full Thread | 200 | 9600 |
| 4.5x25 | Pozidrive1 | Full Thread | 200 | 9600 |

| Screw Size | Screw Head | Description | Quantity | |
|------------|------------|-------------|----------|-------|
| | | | Box | Outer |
| 4.5x30 | Pozidrive1 | Full Thread | 200 | 4800 |
| 4.5x35 | Pozidrive1 | Full Thread | 200 | 4800 |
| 4.5x40 | Pozidrive1 | Full Thread | 200 | 4800 |
| 4.5x45 | Pozidrive1 | Full Thread | 200 | 4800 |
| 4.5x50 | Pozidrive1 | Full Thread | 200 | 4800 |
| 4.8x60 | Pozidrive1 | Full Thread | 200 | 3600 |
| 4.5x70 | Pozidrive1 | Full Thread | 200 | 3600 |
| 4.5x80 | Pozidrive1 | Full Thread | 200 | 2400 |
| 5.0x20 | Pozidrive1 | Full Thread | 200 | 9600 |
| 5.0x25 | Pozidrive1 | Full Thread | 200 | 4800 |
| 5.0x30 | Pozidrive1 | Full Thread | 200 | 4800 |
| 5.0x35 | Pozidrive1 | Full Thread | 200 | 4800 |
| 5.0x40 | Pozidrive1 | Full Thread | 200 | 4800 |
| 5.0x45 | Pozidrive1 | Full Thread | 200 | 4800 |
| 5.0x50 | Pozidrive1 | Full Thread | 200 | 4800 |
| 5.0x60 | Pozidrive1 | Full Thread | 200 | 2400 |
| 5.0x70 | Pozidrive1 | Full Thread | 200 | 2400 |
| 5.0x80 | Pozidrive1 | Full Thread | 200 | 2400 |
| 5.0x90 | Pozidrive1 | Full Thread | 200 | 1200 |
| 5.0x100 | Pozidrive1 | Full Thread | 200 | 1200 |
| 5.0x120 | Pozidrive1 | Full Thread | 200 | 1200 |
| 6.0x30 | Pozidrive1 | Full Thread | 200 | 4800 |
| 6.0x35 | Pozidrive1 | Full Thread | 200 | 4800 |
| 6.0x40 | Pozidrive1 | Full Thread | 200 | 4800 |
| 6.0x50 | Pozidrive1 | Full Thread | 200 | 2400 |
| 6.0x60 | Pozidrive1 | Full Thread | 200 | 2400 |
| 6.0x70 | Pozidrive1 | Full Thread | 200 | 1200 |
| 6.0x80 | Pozidrive1 | Full Thread | 200 | 1200 |
| 6.0x90 | Pozidrive1 | Full Thread | 200 | 1200 |
| 6.0x100 | Pozidrive1 | Full Thread | 200 | 1200 |
| 6.0x110 | Pozidrive1 | Full Thread | 200 | 1200 |
| 6.0x120 | Pozidrive1 | Full Thread | 200 | 1200 |
| 6.0x130 | Pozidrive1 | Full Thread | 200 | 1200 |
| 6.0x140 | Pozidrive1 | Full Thread | 200 | 1200 |
| 6.0x150 | Pozidrive1 | Full Thread | 200 | 1200 |
| 6.0x160 | Pozidrive1 | Full Thread | 200 | 1200 |



CONCRETE SCREW



ADVANTAGES

- Minimum screw anchorage depth:**
 - for dense building materials - 30 mm, for aerated concrete and timber 60mm.
- Screw:**
 - Hardened steel, electro-zinc coated - 10 11m.

APPLICATIONS

- Door and window frames
- Securing formwork
- M & E installation
- Suspended ceilings
- Lightweight steel angles

| Dimensions | Min. embedment depth K*(mm) | Min. embedment depth K**(mm) | Max. fixture thickness u**(mm) | Max. fixture thickness u** (mm) | Quantity Box |
|------------|-----------------------------|------------------------------|--------------------------------|---------------------------------|--------------|
| 7.5x42 | 30 | 60 | 10 | | 100 |
| 7.5x52 | 30 | 60 | 20 | | 100 |
| 7.5x62 | 30 | 60 | 30 | | 100 |
| 7.5x72 | 30 | 60 | 40 | 10 | 100 |
| 7.5x82 | 30 | 60 | 50 | 20 | 100 |
| 7.5x92 | 30 | 60 | 60 | 30 | 100 |
| 7.5x100 | 30 | 60 | | | 100 |
| 7.5x112 | 30 | 60 | 80 | 50 | 100 |
| 7.5x120 | 30 | 60 | | | 100 |
| 7.5x132 | 30 | 60 | 100 | 70 | 100 |
| 7.5x152 | 30 | 60 | 150 | 120 | 100 |
| 7.5x182 | 30 | 60 | 150 | 120 | 100 |
| 7.5x202 | 30 | 60 | 170 | 140 | 100 |
| 7.5x212 | 30 | 60 | 180 | 150 | 100 |

CONFIRMATIVE SCREW-HEX DRIVE POZI DRIVE



ADVANTAGES

- A self-countersinking head eliminates the need to pre-countersink holes, saving time and tool costs.
- Pointed tip makes it easier to drive the Confirmat and compensates for slightly misaligned parts.
- Economical and easy installation makes Confirmative very cost effective.

APPLICATIONS

- Allows installation in visible spots through the use of a wide range of cover caps in a variety of colors.
- Tapered tip with cutting teeth threads the wood, insuring wood will not split.
- Complete range of supporting equipment tools available.

| Size /mm | N.W.(g/pcs) | Pcs/carton |
|----------|-------------|------------|
| 5*40 | 3.2 | 4000 |
| 5*50 | 3.9 | 3000 |
| 6.3*50 | 6.2 | 2500 |
| 7*40 | 5.9 | 2500 |
| 7*50 | 7.2 | 2000 |
| 7*70 | 10.5 | 1500 |
| 7*85 | 18.5 | 1000 |



DIN 3570 U BOLT

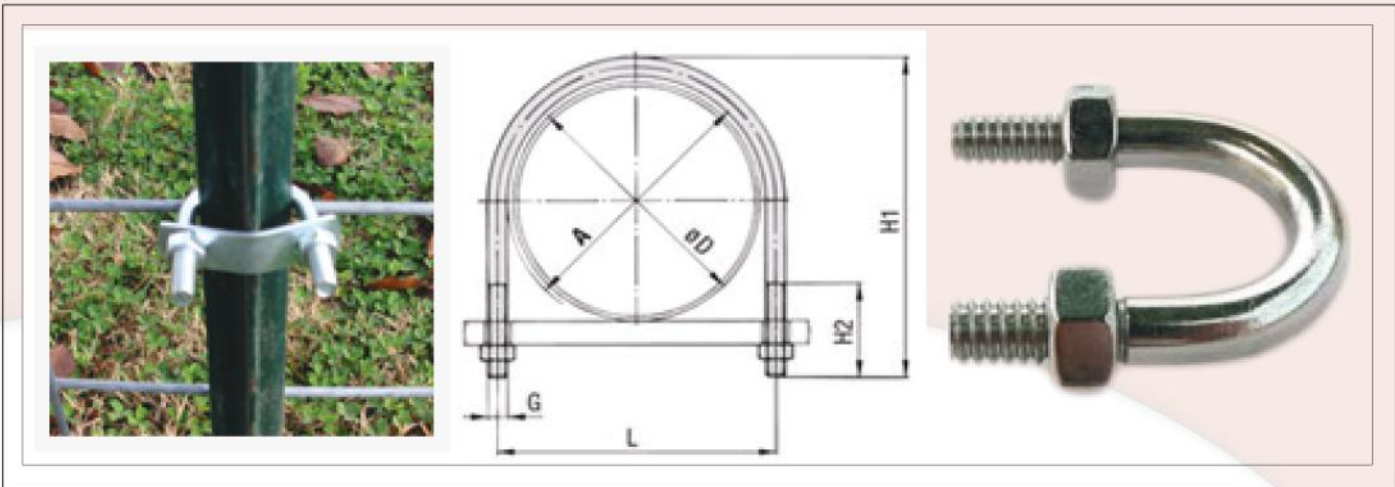

| DN | AD ϕ D | | RBO | | | | |
|-----|-------------|------------------|-----|-----|-----|----|-----|
| | [mm] | min width | A | L | H | H2 | G |
| 20 | 25 | | 30 | 40 | 70 | 40 | M10 |
| | 26,9 | 3/4 | | | | | |
| 25 | 30 | | 38 | 48 | 76 | | |
| | 33,7 | 1 | | | | | |
| 32 | 38 | | 46 | 56 | 86 | | |
| | 42,4 | 1 ^{1/4} | | | | | |
| 40 | 44,5 | | 52 | 62 | 92 | 50 | M12 |
| | 48,3 | 1 ^{1/2} | | | | | |
| 50 | 57 | | 64 | 76 | 109 | | |
| | 60,3 | 2 | | | | | |
| 65 | 76,1 | 2 ^{1/2} | 82 | 94 | 125 | | |
| 80 | 88,9 | 3 | 94 | 106 | 138 | | |
| 100 | 108 | | 120 | 136 | 171 | 60 | M16 |
| | 114,3 | 4 | | | | | |
| 125 | 133 | | 148 | 164 | 191 | | |
| | 139,7 | 5 | | | | | |
| 150 | 159 | | 176 | 192 | 217 | | |
| | 168,3 | 6 | | | | | |
| 175 | 193,7 | | 202 | 218 | 249 | | |
| 200 | 216 | | 228 | 248 | 283 | 70 | M20 |
| | 219,1 | 8 | | | | | |
| 250 | 267 | | 282 | 302 | 334 | | |
| | 273 | 10 | | | | | |
| 300 | 318 | | 332 | 352 | 385 | | |
| | 323,9 | 12 | | | | | |
| 350 | 355,6 | 14 | 378 | 402 | 435 | | |
| | 368 | | | | | | |
| 400 | 406,4 | 16 | 428 | 452 | 487 | | |
| | 419 | | | | | | |
| 500 | 508 | | 530 | 554 | 589 | | |
| | 521 | | | | | | |



CAN U CLAMP



| Clamping Size | Nominal Pipe Size | | Width X Thickness |
|---------------|-------------------|-------|-------------------|
| | [mm] | Inch | |
| 16 | 10 | 3/8' | 16 |
| 22 | 15 | 1/2' | 22 |
| 25 | 17 | 5/8 | 25 |
| 27 | 20 | 3/4 | 27 |
| 34 | 25 | 1 | 34 |
| 43 | 32 | 1 1/4 | 43 |
| 49 | 40 | 1 1/2 | 49 |
| 61 | 50 | 2 | 61 |
| 77 | 65 | 2 1/2 | 77 |
| 90 | 80 | 3 | 90 |
| 115 | 100 | 4 | 115 |
| 141 | 125 | 5 | 141 |
| 166 | 140 | 6 | 166 |
| 215 | 200 | 8 | 215 |

CAN SPRINKLER HANGER



| Nominal Pipe Size | | Rod Size | Width X Thickness |
|-------------------|-------|----------|-------------------|
| Inches | [mm] | [mm] | [mm] |
| 15 | 1/2 | 8/10 | 25x1.5 |
| 20 | 3/4 | 8/10 | 25x1.5 |
| 25 | 1 | 8/10 | 25x1.5 |
| 32 | 1 1/4 | 8/10 | 25x1.5 |
| 40 | 1 1/2 | 8/10 | 25x1.5 |
| 50 | 2 | 8/10 | 25x2.5 |
| 65 | 2 1/2 | 10 | 25x2.5 |
| 80 | 3 | 10 | 25x2.5 |
| 100 | 4 | 12 | 25x2.5 |
| 125 | 5 | 12 | 30x3.0 |
| 150 | 6 | 16 | 30x3.0 |
| 200 | 8 | 16 | 38x3.0 |

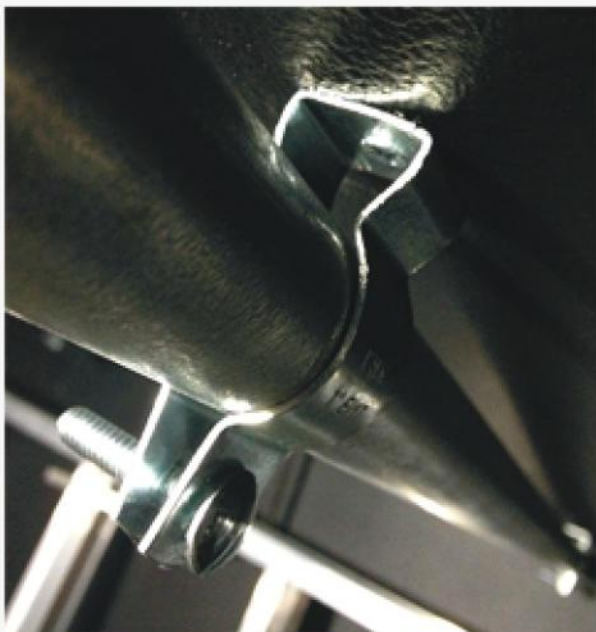



CAN PIPE CLAMP WITH RUBBER



CAN PIPE CLAMP



| ϕ [mm] | Inches | Width X Thickness [mm] |
|-------------|--------|------------------------|
| 15-19 | 3/8 | 20X1.8 |
| 20-25 | 1/2 | 20X1.8 |
| 26-30 | 3/4 | 20X1.8 |
| 32-36 | 1 | 20X2.0 |
| 38-45 | 1 1/4 | 20X2.0 |
| 47-51 | 1 1/2 | 20X2.0 |
| 53-58 | - | 20X2.0 |
| 60-64 | 2 | 20X2.2 |
| 68-72 | - | 20X2.2 |
| 74-80 | 2 1/2 | 20X2.2 |
| 81-86 | - | 20X2.2 |
| 87-92 | 3 | 20X2.4 |
| 99-105 | 3 1/2 | 20X2.4 |
| 107-112 | - | 20X2.4 |
| 113-118 | 4 | 20X2.5 |
| 125-130 | - | 20X2.5 |
| 131-137 | - | 20X2.5 |
| 138-142 | 5 | 20X2.5 |
| 148-152 | - | 20X2.5 |
| 159-160 | 6 | 20X2.5 |
| 168-172 | - | 20X2.5 |
| 200-205 | - | 20X2.5 |
| 215-220 | - | 20X2.5 |





| Thickness | Width | Length |
|-----------|-------|--------|
| 2.5 | 20 | 20 |
| 2.5 | 20 | 25 |
| 2.5 | 20 | 30 |
| 2.5 | 25 | 30 |
| 2.5 | 25 | 40 |
| 2.5 | 25 | 50 |
| 2.5 | 25 | 60 |
| 2.5 | 25 | 70 |
| 2.5 | 25 | 100 |

CAN PIN WITH RING



| Size |
|------|
| 4X40 |
| 4X50 |
| 4X50 |
| 4X60 |
| 6X60 |





DIN 931 HEXAGONAL HEAD SCREW DIN933 HEXAGON WOOD SCREW

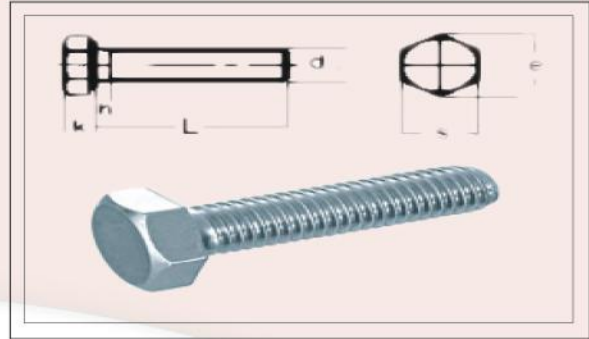
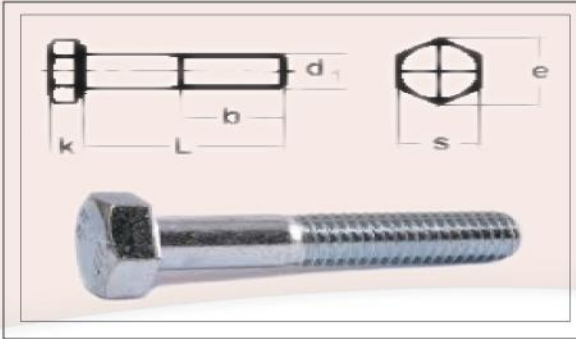

| d_1 | k | s | $b_{L>125}$ | $b_{L>125}$ | $b_{L>200}$ | e |
|-------------------|------|--------|-------------|-------------|-------------|--------|
| M3 | 2 | 5.5 | 12 | - | - | 6.01 |
| M4 | 2.8 | 7 | 14 | - | - | 7.66 |
| M5 | 3.5 | 8 | 16 | - | - | 8.79 |
| M6 | 4 | 10 | 18 | 24 | - | 11.05 |
| M7 | 4.8 | 11 | 20 | 26 | - | 12.12 |
| M8 | 5.3 | 13 | 22 | 28 | - | 14.38 |
| M10 ¹⁾ | 6.4 | 16(17) | 26 | 32 | 45 | 18.90 |
| M12 ¹⁾ | 7.5 | 18(19) | 30 | 36 | 49 | 21.10 |
| M14 ¹⁾ | 8.8 | 21(22) | 34 | 40 | 53 | 24.49 |
| M16 | 10 | 24 | 38 | 44 | 57 | 26.75 |
| M18 | 11.5 | 27 | 42 | 48 | 61 | 30.14 |
| M20 | 12.5 | 30 | 46 | 52 | 65 | 33.53 |
| M22 ¹⁾ | 14 | 34(32) | 50 | 56 | 69 | 35.72 |
| M24 | 15 | 36 | 54 | 60 | 73 | 39.98 |
| M27 | 17 | 41 | 60 | 66 | 79 | 45.20 |
| M30 | 18.7 | 46 | 66 | 72 | 85 | 50.85 |
| M33 | 21 | 50 | 72 | 78 | 91 | 55.37 |
| M36 | 22.5 | 55 | 78 | 84 | 97 | 60.79 |
| M39 | 25 | 60 | 84 | 90 | 103 | 66.44 |
| M42 | 26 | 65 | 90 | 96 | 109 | 71.30 |
| M45 | 28 | 70 | 96 | 102 | 115 | 76.95 |
| M48 | 30 | 75 | 102 | 108 | 121 | 82.25 |
| M52 | 33 | 80 | - | 116 | 129 | 88.25 |
| M56 | 35 | 85 | - | 124 | 137 | 93.56 |
| M60 | 38 | 90 | - | 132 | 145 | 99.21 |
| M64 | 40 | 95 | - | 140 | 153 | 104.86 |

| d_1 | k | s | e | h_{max} |
|-------------------|------|--------|--------|-----------|
| M1.6 | 1.1 | 3.2 | 3.48 | - |
| M2 | 1.4 | 4 | 4.32 | 1.7 |
| M2.5 | 1.7 | 5 | 5.45 | - |
| M3 | 2 | 5.5 | 6.01 | 1.5 |
| M3.5 | 2.4 | 6 | 6.58 | - |
| M4 | 2.8 | 7 | 7.66 | 2.1 |
| M5 | 3.5 | 8 | 8.79 | 2.4 |
| M6 | 4 | 10 | 11.05 | 3 |
| M7 | 4.8 | 11 | 14.38 | 3.75 |
| M8 | 5.3 | 13 | 18.90 | 4.5 |
| M10 ¹⁾ | 6.4 | 16(17) | 18.90 | 4.5 |
| M12 ¹⁾ | 7.5 | 18(19) | 21.22 | 5.25 |
| M14 ¹⁾ | 8.8 | 21(22) | 24.49 | 6 |
| M16 | 10 | 24 | 26.75 | 6 |
| M18 | 11.5 | 27 | 30.14 | 7.5 |
| M20 | 12.5 | 30 | 33.53 | 7.5 |
| M22 ¹⁾ | 14 | 34(32) | 35.72 | 7.5 |
| M24 | 15 | 36 | 39.98 | 9 |
| M27 | 17 | 41 | 45.20 | 9 |
| M30 | 18.7 | 46 | 50.85 | 10.5 |
| M33 | 21 | 50 | 55.37 | 10.5 |
| M36 | 22.5 | 55 | 60.79 | 12 |
| M39 | 25 | 60 | 66.44 | - |
| M42 | 26 | 65 | 71.30 | - |
| M45 | 28 | 70 | 76.95 | - |
| M48 | 30 | 75 | 82.60 | - |
| M52 | 33 | 80 | 88.25 | - |
| M64 | 40 | 95 | 104.86 | - |

DIN 603 MUSHROOM HEAD SQUARE NECK BOLT

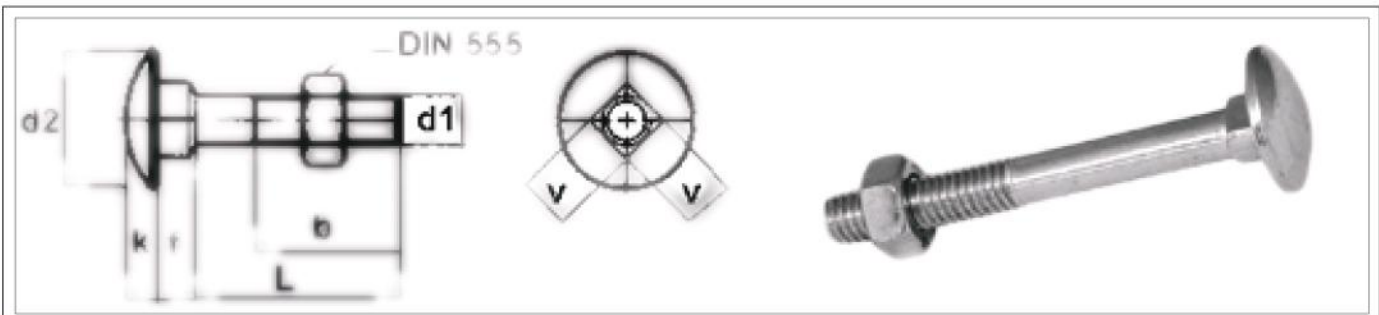

| d_1 | $b_{L>25-200}$ | $b_{L>200}$ | $d2_{max}$ | k_{max} | f_{max} | v_{max} |
|-------|----------------|-------------|------------|-----------|-----------|-----------|
| M5 | 22 | | 13.55 | 3.3 | 4.1 | 5.48 |
| M6 | 24 | | 16.55 | 3.88 | 4.6 | 6.48 |
| M8 | 28 | 41 | 20.65 | 4.88 | 5.6 | 8.58 |
| M10 | 32 | 45 | 24.65 | 5.38 | 6.6 | 10.58 |
| M12 | 36 | 49 | 30.65 | 6.95 | 8.75 | 12.7 |
| M16 | 44 | 57 | 38.8 | 8.95 | 12.9 | 16.7 |



DIN 571 HEXAGON HEAD WOOD SCREW

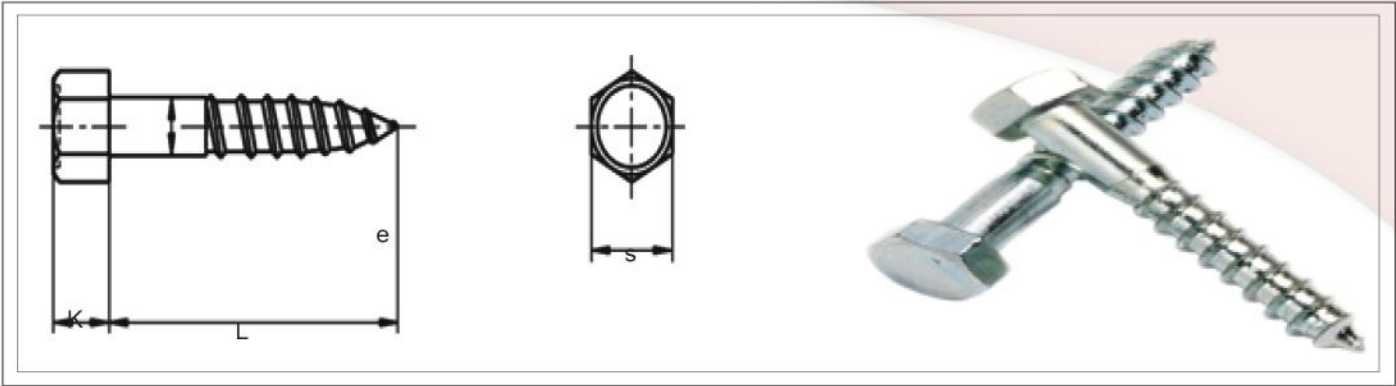

| Thead Size | k | e | s | | | | L |
|------------|-------|--------|--------|--------|--------|--------|--------|
| 4 | 5 | 6 | 7 | 8 | 10 | 12 | 16 |
| 2.8 | 3.5 | 4 | 5 | 5.5 | 7 | 8 | 10 |
| 7.50 | 8.63 | 10.89 | 13.07 | 14.2 | 18.72 | 20.88 | 26.17 |
| 7 | 8 | 10 | 12 | 13 | 17 | 19 | 24 |
| 16-40 | 16-50 | 25-150 | 30-150 | 30-200 | 30-300 | 35-400 | 45-420 |

DIN 912-SOCKET HEAD CAP SCREWS

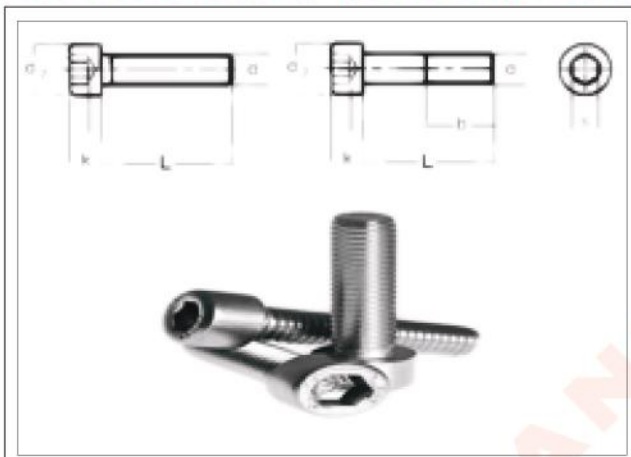

| | | | | | | |
|-------------------|----|-----|----|----|------|-----|
| M24 | 36 | 60 | 24 | 19 | 12 | 80 |
| M27 ²⁾ | 40 | 66 | 27 | 19 | 13.5 | 90 |
| M30 | 45 | 72 | 30 | 22 | 15.5 | 100 |
| M33 | 50 | 78 | 33 | 24 | 18 | 100 |
| M36 | 54 | 84 | 36 | 27 | 19 | 110 |
| M42 ²⁾ | 63 | 96 | 42 | 32 | 24 | 130 |
| M48 | 72 | 108 | 48 | 36 | 28 | 150 |
| M52 | 78 | 116 | 52 | 36 | 31 | - |
| M56 | 84 | 124 | 56 | 36 | 34 | - |
| M64 | 96 | 140 | 64 | 46 | 38 | - |

DIN 6912-SOCKET HEAD CAP SCREWS

| d ₁ | d ₂ | b | k | s | t _{min} | d _c ¹⁾ |
|-------------------|----------------|----|-----|------|------------------|------------------------------|
| M1.4 | 2.6 | - | 1.4 | 1.25 | - | 12 |
| M1.6 | 3 | 15 | 1.6 | 1.5 | 0.7 | 16 |
| M1.8 | 3.4 | - | 1.8 | 1.5 | 1 | 16 |
| M2 | 3.8 | 16 | 2 | 1.5 | 1 | 20 |
| M2.5 | 4.5 | 17 | 2.5 | 2 | 1.1 | 25 |
| M3 | 5.5 | 18 | 3 | 2.5 | 1.3 | 20 |
| M4 | 7 | 20 | 4 | 3 | 2 | 25 |
| M5 | 8.5 | 22 | 5 | 4 | 2.5 | 25 |
| M6 | 10 | 24 | 6 | 5 | 3 | 30 |
| M8 | 13 | 28 | 8 | 6 | 4 | 35 |
| M10 | 16 | 32 | 10 | 8 | 5 | 40 |
| M12 | 18 | 36 | 12 | 10 | 6 | 50 |
| M14 | 21 | 40 | 14 | 12 | 7 | 55 |
| M16 | 24 | 44 | 16 | 14 | 8 | 60 |
| M18 ²⁾ | 27 | 48 | 18 | 14 | 9 | 65 |
| M20 | 30 | 52 | 20 | 17 | 10 | 70 |
| M22 | 33 | 56 | 22 | 17 | 11 | 75 |

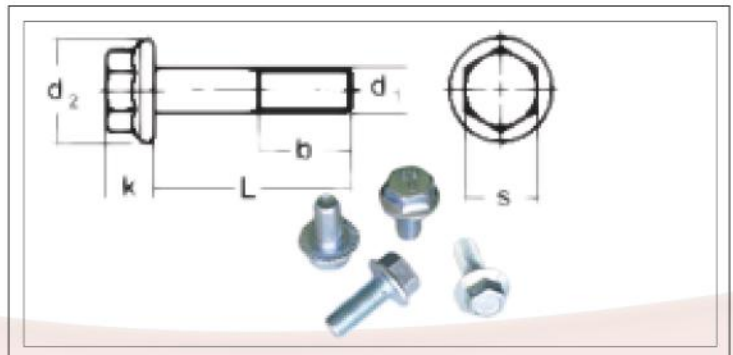

| d ₁ | d ₂ | k | s | d _{L<125} | d _{L>125} | d _{L<} ¹⁾ |
|----------------|----------------|------|----|-----------------------|-----------------------|----------------------------------|
| M6 | 14.2 | 6.6 | 10 | 18 | - | 20 |
| M8 | 18 | 8.1 | 13 | 22 | 28 | 30 |
| M10 | 22.3 | 11.5 | 16 | 30 | 36 | 40 |
| M12 | 26.6 | 11.5 | 16 | 30 | 36 | 40 |
| M14 | 30.5 | 14.4 | 18 | 34 | 40 | 45 |
| M16 | 35 | 14.4 | 21 | 38 | 44 | 50 |
| M20 | 43 | 17.1 | 27 | 46 | 52 | 60 |



DIN 934 HEX NUT



| d_1 | $s^{(1)}$ | $m_{(max1)}$ | e_{min} |
|-------|-----------|--------------|--------------|
| M1 | 2.5 | 0.8 | 2.71 |
| M1.2 | 3 | 1.2 | 3.28 |
| M1.4 | 3 | 1.3 | 3.48 |
| M1.6 | 3.2 | 1.3 | 3.48 |
| M1.7 | 3.5 | 1.4 | 3.82 |
| M1.8 | 3.5 | 1.4 | 3.82 |
| M2 | 4 | 1.6 | 4.32 |
| M2.3 | 4.5 | 1.8 | 4.88 |
| M2.5 | 5 | 2 | 5.45 |
| M2.6 | 5 | 2 | 5.45 |
| M3 | 5.5 | 2.4 | 6.01 |
| M4 | 7 | 3.2 | 7.68 |
| M5 | 8 | 4.7(4) | 8.79 |
| M6 | 10 | 4.2(5) | 11.05 |
| M7 | 11 | 5.5 | 12.12 |
| M8 | 13 | 6.8(6.5) | 14.38 |
| M10 | 16(17) | 8.4(8) | 17.77(18.90) |
| M12 | 18(19) | 10.8(10) | 20.35(21.10) |
| M14 | 21(22) | 12.8(11) | 23.35(24.49) |
| M16 | 24 | 14.8 (13) | 26.75 |
| M18 | 27 | 15.8(15) | 29.56 |
| M20 | 30 | 18.0(16) | 32.95 |
| M22 | 34(32) | 19.4(18) | 37.29(35.03) |
| M24 | 36 | 21.5(19) | 39.55 |

| | | | |
|------|-----|----------|--------|
| M27 | 41 | 23.8(22) | 45.20 |
| M30 | 46 | 25.6(24) | 50.85 |
| M33 | 50 | 28.7(26) | 55.37 |
| M36 | 55 | 33.4(31) | 66.79 |
| M39 | 60 | 33.4(31) | 66.44 |
| M42 | 65 | 34 | 71.30 |
| M45 | 70 | 36 | 76.95 |
| M48 | 75 | 38 | 82.60 |
| M52 | 80 | 42 | 88.25 |
| M56 | 85 | 45 | 93.56 |
| M60 | 90 | 48 | 99.21 |
| M64 | 95 | 51 | 104.86 |
| M68 | 100 | 54 | 110.81 |
| M72 | 105 | 58 | 116.16 |
| M76 | 110 | 61 | 121.81 |
| M80 | 115 | 64 | 127.46 |
| M85 | 120 | 68 | 133.11 |
| M90 | 130 | 72 | 144.08 |
| M95 | 135 | 76 | 150.74 |
| M100 | 145 | 80 | 161.02 |
| M105 | 150 | 84 | 167.69 |
| M110 | 155 | 88 | 172.32 |
| M120 | 170 | 96 | 190.29 |
| M125 | 180 | 100 | 200.57 |
| M140 | 200 | 112 | 220.80 |

DIN 982 SELF LOCKING NUT

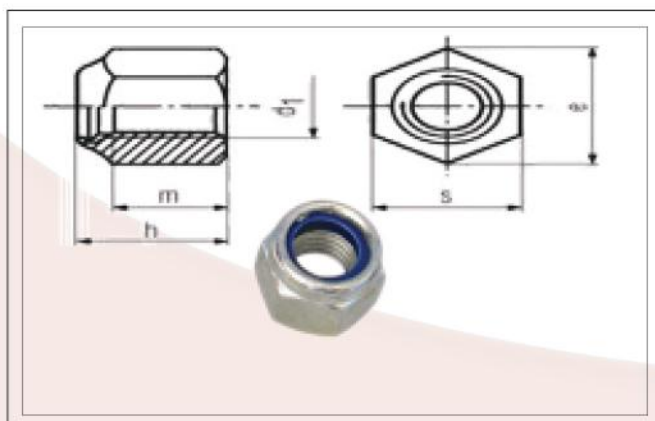

| d_1 | s | h | m | e_{min} |
|-------|-----|------|-------|-----------|
| M5 | 8 | 6.3 | 4.4 | 8.79 |
| M6 | 10 | 8 | 4.9 | 11.05 |
| M7 | 11 | 8.5 | 6.14 | 12.12 |
| M8 | 13 | 9.5 | 6.44 | 14.38 |
| M10 | 17 | 11.5 | 8.04 | 18.90 |
| M12 | 19 | 14 | 10.37 | 21.10 |
| M14 | 22 | 16 | 12.1 | 24.49 |
| M16 | 24 | 18 | 14.1 | 26.75 |
| M18 | 27 | 20 | 15.1 | 29.56 |
| M20 | 30 | 22 | 16.9 | 32.95 |
| M22 | 32 | 25 | 18.1 | 35.03 |
| M24 | 36 | 28 | 20.2 | 39.55 |



DIN 985 NYLON INSERT LOCK NUT

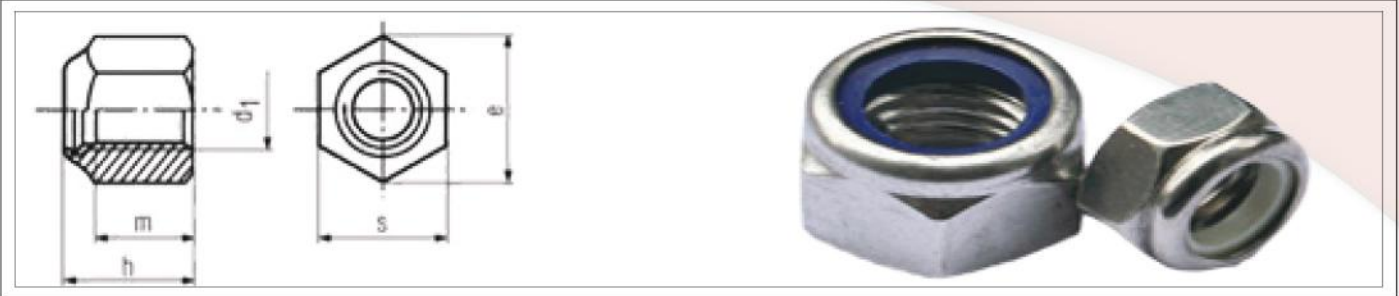

| d_1 | s | h_{max} | m | e_{min} |
|-------|-----|-----------|-----|-----------|
| M2 | 4.5 | 2.5 | 1.6 | 4.91 |
| M2.5 | 5 | 3.8 | 2 | 5.51 |
| M,3 | 5.5 | 4 | 2.4 | 6.01 |
| M3.5 | 6 | 4.5 | 2.6 | 6.64 |
| M4 | 7 | 5 | 3.2 | 7.66 |
| M5 | 8 | 5 | 4 | 8.79 |
| M6 | 10 | 6 | 5 | 11.05 |
| M7 | 11 | 7.5 | 5.5 | 12.12 |
| M8 | 13 | 8 | 6.5 | 14.38 |
| M10 | 17 | 10 | 8 | 18.90 |
| M12 | 19 | 12 | 10 | 21.10 |
| M14 | 22 | 14 | 11 | 24.49 |
| M16 | 24 | 16 | 13 | 26.75 |
| M18 | 27 | 18.5 | 15 | 29.56 |

| | | | | |
|-----|----|----|----|-------|
| M20 | 30 | 20 | 16 | 32.95 |
| M22 | 32 | 22 | 18 | 35.03 |
| M24 | 36 | 55 | 19 | 39.55 |
| M27 | 41 | 27 | 22 | 45.20 |
| M30 | 46 | 30 | 24 | 50.85 |
| M33 | 50 | 33 | 26 | 55.37 |
| M36 | 55 | 36 | 29 | 60.79 |
| M39 | 60 | 39 | 31 | 66.44 |
| M42 | 65 | 42 | 34 | 71.30 |
| M45 | 70 | 45 | 36 | 76.95 |
| M48 | 75 | 48 | 38 | 82.60 |
| M52 | 80 | 52 | 42 | 88.25 |
| M56 | 85 | 56 | 45 | - |
| M60 | 90 | 60 | 48 | - |
| M64 | 95 | 64 | 41 | - |

DIN 1587 HEXAGON DOMED CAP NUT

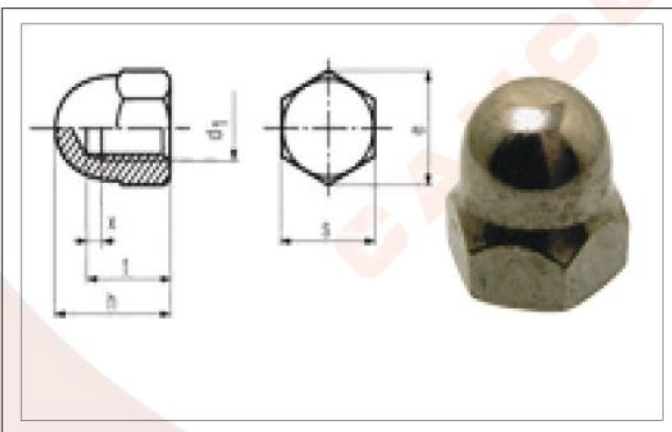

| d_1 | s | h | t | b | e_{min} |
|-------------------|--------|----|-----|------|--------------|
| M3 | 5.5 | 6 | 3.8 | 2.8 | 6.01 |
| M4 | 7 | 8 | 5.5 | 4.1 | 7.66 |
| M5 | 8 | 10 | 7.5 | 5.4 | 8.79 |
| M6 | 10 | 12 | 8 | 8 | 11.05 |
| M8 | 13 | 15 | 11 | 8.5 | 14.38 |
| M10 ¹⁾ | 16(17) | 18 | 13 | 10 | 17.77(18.90) |
| M12 ¹⁾ | 18(19) | 22 | 28 | 21 | 20.03(21.10) |
| M14 ¹⁾ | 21(22) | 25 | 18 | 13 | 23.35(24.49) |
| M16 | 24 | 28 | 21 | 16 | 26.75 |
| M18 | 27 | 32 | 25 | 18.7 | 29.56 |
| M20 | 30 | 34 | 26 | 19.7 | 32.95 |
| M22 ¹⁾ | 34(32) | 39 | 29 | 22.7 | 37.29(35.03) |
| M24 | 36 | 42 | 31 | 23.5 | 39.55 |
| M27 | 41 | 48 | - | - | 45.20 |
| M30 | 45 | 55 | - | - | 50.85 |

DIN 986 DOME NUT

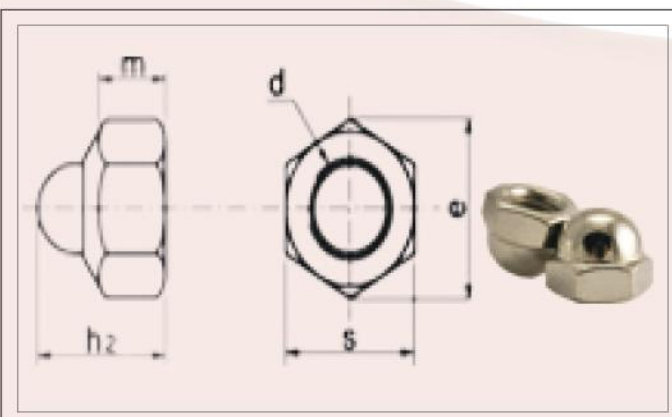

| d_1 | s | h | m | e_{min} |
|-------------------|--------|-------|-------|--------------|
| M4 | 7 | 9.6 | 2.9 | 7.66 |
| M5 | 8 | 10.65 | 4.4 | 8.79 |
| M6 | 10 | 12 | 4.9 | 11.05 |
| M8 | 13 | 14 | 6.44 | 14.38 |
| M10 ¹⁾ | 16(17) | 18.1 | 8.04 | 17.77(18.90) |
| M12 ¹⁾ | 18(19) | 22.5 | 10.37 | 20.03(21.10) |
| M16 | 24 | 27.5 | 14.1 | 26.75 |
| M20 | 30 | 35 | 16.9 | 32.95 |



DIN 6923 HEXAGON FLANGE NUT

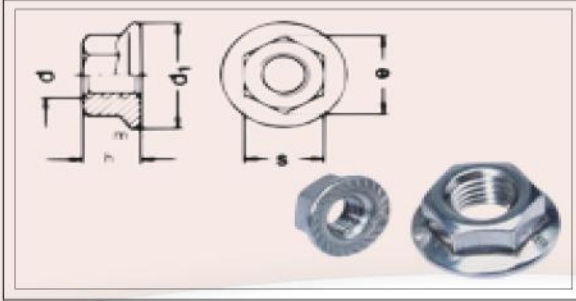

| d | d _{1max} | s | h _{max} | m _{min} |
|-----|-------------------|----|------------------|------------------|
| M5 | 11.8 | 8 | 5 | - |
| M6 | 14.2 | 10 | 6 | 31 |
| M8 | 17.9 | 13 | 8 | 4.5 |
| M10 | 21.8 | 15 | 10 | 5.5 |
| M12 | 26 | 18 | 12 | 6.7 |
| M14 | 29.9 | 21 | 14 | 7.8 |
| M16 | 34.5 | 24 | 16 | 9 |
| M20 | 42.8 | 30 | 20 | - |
| M24 | 45 | 36 | 30 | - |

DIN 315 WING NUT

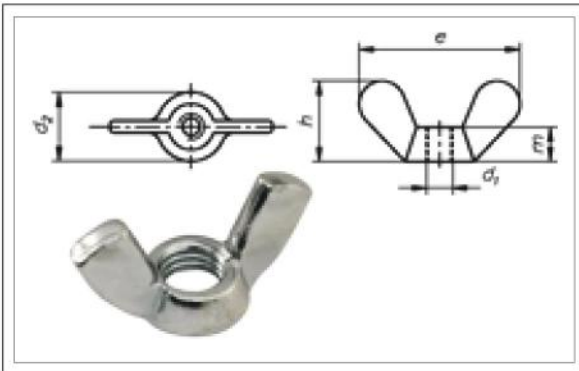

| d ₁ | d _{2max} | m | h _{max} | g _{max} | e _{min} |
|----------------|-------------------|-----|------------------|------------------|------------------|
| M3 | 8 | - | 10 | 1.6 | 20 |
| M4 | 8 | 4.6 | 10.5 | 1.9 | 20 |
| M5 | 11 | 6.5 | 13 | 2.3 | 26 |
| M6 | 13 | 8 | 17 | 2.3 | 33 |
| M8 | 16 | 10 | 20 | 2.8 | 39 |
| M10 | 20 | 12 | 25 | 4.4 | 51 |
| M12 | 23 | 14 | 33.65 | 4.9 | 65 |
| M14 | - | 17 | 37.5 | - | 73 |
| M16 | 29 | 17 | 37.5 | 6.4 | 73 |
| M20 | 35 | 21 | 46.5 | 6.9 | 90 |
| M24 | 44 | 25 | 56.5 | 9.4 | 110 |

DIN 6334 ROD CONNECTOR

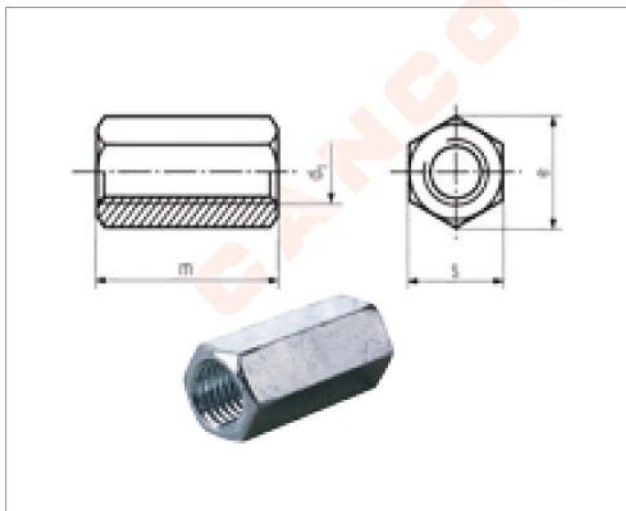

| d ₁ | s | m _{max} | e _{min} |
|-------------------|--------|------------------|------------------|
| M5 | 8 | 15 | 8.79 |
| M6 | 10 | 18 | 11.05 |
| M8 | 13 | 24 | 14.38 |
| M10 ¹⁾ | 16(17) | 30 | 17.77(18.90) |
| M12 ¹⁾ | 18(19) | 36 | 20.03(21.49) |
| M14 ¹⁾ | 21(22) | 42 | 23.35(24.49) |
| M16 | 24 | 48 | 26.75 |
| M18 | 27 | 54 | 29.56 |
| M20 | 30 | 60 | 32.95 |
| M22 ¹⁾ | 34(32) | 66 | 37.29(35.03) |
| M24 | 36 | 72 | 39.55 |
| M30 | 46 | 90 | 50.85 |
| M36 | 55 | 108 | 60.79 |
| M42 | 65 | 126 | 71.30 |
| M48 | 75 | 144 | 82.60 |

DIN 935 HEX CASTLE SLOTTED NUT

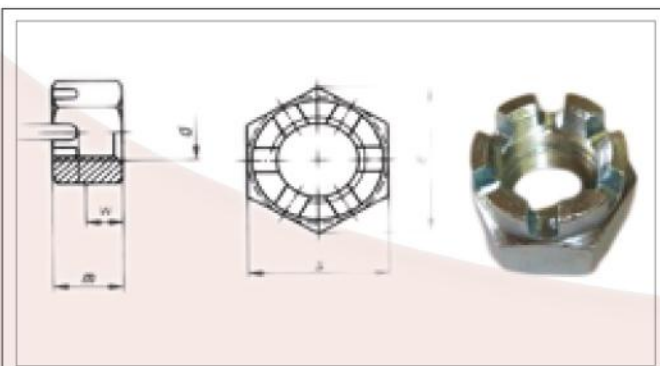

| d | s | e | m | w max |
|-----|----|-------|-----|-------|
| M5 | 8 | 8,79 | 6 | 4 |
| M6 | 10 | 11,05 | 7,5 | 5 |
| M8 | 13 | 14,38 | 9,5 | 6,5 |
| M10 | 17 | 18,9 | 12 | 8 |
| M12 | 19 | 21,1 | 15 | 10 |
| M14 | 22 | 24,49 | 16 | 11 |
| M16 | 24 | 26,75 | 19 | 13 |
| M18 | 27 | 29,56 | 21 | 15 |



DIN 125 FLAT WASHER

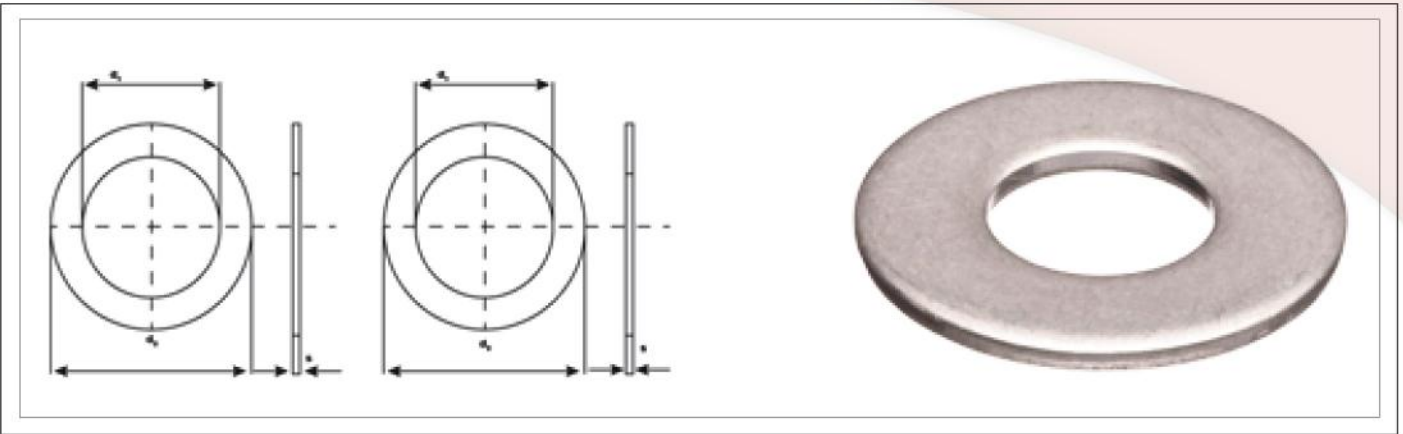

| d_1 | Used for | d_2 | s |
|-------|----------|-------|-----|
| 1.1 | M1 | 3 | 0.3 |
| 1.3 | M1.2 | 3.5 | 0.3 |
| 1.5 | M1.4 | 4 | 0.3 |
| 1.7 | M1.6 | 4 | 0.3 |
| 1.8 | M1.7 | 4.5 | 0.3 |
| 2.2 | M2 | 5 | 0.3 |
| 2.7 | M2.5 | 6 | 0.5 |
| 2.8 | M2.6 | 7 | 0.5 |
| 3.2 | M3 | 7 | 0.5 |
| 3.7 | M3.5 | 8 | 0.5 |
| 4.3 | M4 | 9 | 0.8 |
| 5.3 | M5 | 10 | 1 |
| 6.4 | M6 | 12 | 1.6 |
| 7.4 | M7 | 14 | 1.6 |
| 8.4 | M8 | 16 | 1.6 |
| 10.5 | M10 | 20 | 2 |
| 13 | M12 | 24 | 2.5 |
| 15 | M14 | 28 | 2.5 |
| 17 | M16 | 30 | 3 |
| 19 | M18 | 34 | 3 |
| 21 | M20 | 37 | 3 |

| | | | |
|-----|------|-----|----|
| 23 | M22 | 39 | 3 |
| 25 | M24 | 44 | 4 |
| 28 | M27 | 50 | 4 |
| 31 | M30 | 56 | 4 |
| 34 | M33 | 60 | 5 |
| 37 | M39 | 72 | 6 |
| 43 | M42 | 45 | 7 |
| 46 | M45 | 85 | 7 |
| 50 | M48 | 92 | 8 |
| 54 | M52 | 98 | 8 |
| 58 | M56 | 105 | 9 |
| 62 | M60 | 110 | 9 |
| 66 | M64 | 115 | 9 |
| 70 | M68 | 120 | 9 |
| 74 | M72 | 125 | 10 |
| 78 | M76 | 135 | 10 |
| 82 | M80 | 140 | 12 |
| 87 | M85 | 145 | 12 |
| 93 | M90 | 160 | 12 |
| 104 | M100 | 175 | 14 |

DIN 7349 STEEL PLAIN WASHER

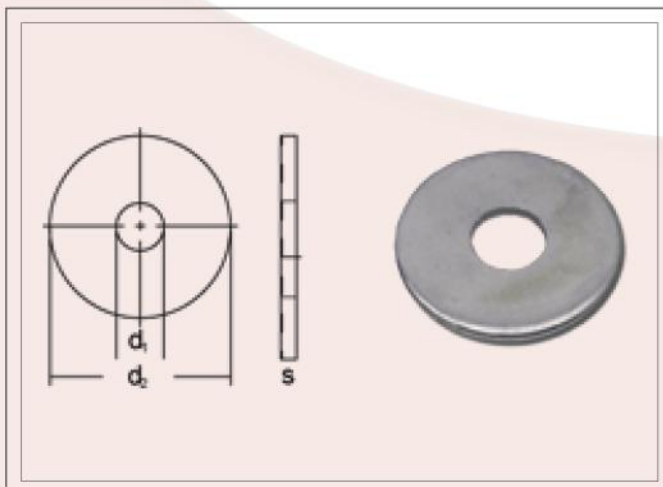

| d_1 | Used for | d_2 | s |
|-------|----------|-------|-----|
| 3.2 | M3 | 9 | 1 |
| 4.3 | M4 | 12 | 1.6 |
| 5.3 | M5 | 15 | 2 |
| 6.4 | M6 | 17 | 3 |
| 8.4 | M8 | 21 | 4 |
| 10.5 | M10 | 25 | 4 |
| 13 | M12 | 30 | 6 |
| 15 | M14 | 36 | 6 |
| 17 | M16 | 40 | 6 |
| 19 | M18 | 44 | 8 |
| 21 | M20 | 50 | 8 |
| 23 | M22 | 50 | 8 |
| 25 | M24 | 50 | 10 |
| 28 | M27 | 60 | 10 |
| 31 | M30 | 68 | 10 |



DIN126 FLAT WASHER



| d_1 | Used for | d_2 | s |
|-------|----------|-------|-----|
| 5.5 | M5 | 10 | 1 |
| 6.6 | M6 | 12 | 1.6 |
| 7.6 | M7 | 14 | 1.6 |
| 9 | M8 | 16 | 1.6 |
| 11 | M10 | 20 | 2 |
| 13.5 | M12 | 24 | 2.5 |
| 15.5 | M14 | 28 | 2.5 |
| 17.5 | M16 | 30 | 3 |
| 22 | M20 | 37 | 3 |
| 24 | M22 | 39 | 3 |
| 26 | M24 | 44 | 4 |
| 30 | M27 | 50 | 4 |
| 33 | M30 | 56 | 4 |

| | | | |
|----|-----|-----|----|
| 36 | M33 | 60 | 5 |
| 39 | M36 | 66 | 5 |
| 42 | M39 | 72 | 6 |
| 45 | M42 | 78 | 7 |
| 48 | M45 | 85 | 7 |
| 52 | M48 | 92 | 8 |
| 56 | M52 | 98 | 8 |
| 62 | M56 | 105 | 9 |
| 66 | M60 | 110 | 9 |
| 70 | M64 | 115 | 9 |
| 78 | M72 | 125 | 10 |
| 86 | M80 | 140 | 12 |
| 96 | M90 | 160 | 12 |

DIN 9021 FLAT WASHER

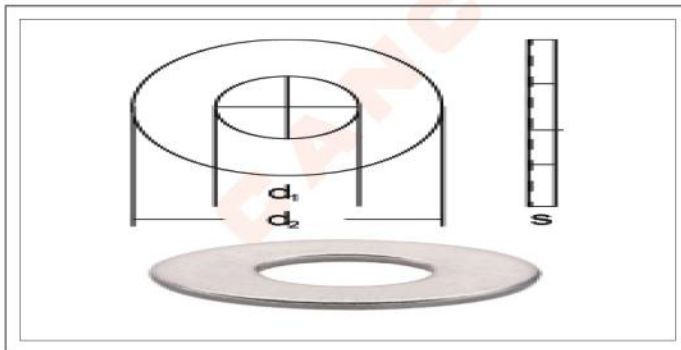

| d_1 | Used for | d_2 | s |
|-------|----------|-------|-----|
| 2.5 | M2.3 | 8 | 0.8 |
| 2.7 | M2.5 | 8 | 0.8 |
| 3.2 | M3 | 9 | 0.8 |
| 3.7 | M3.5 | 11 | 0.8 |
| 4.3 | M4 | 12 | 1 |
| 5.3 | M5 | 15 | 1.2 |
| 6.4 | M6 | 18 | 1.6 |
| 7.4 | M7 | 22 | 2 |
| 8.4 | M8 | 24 | 2 |
| 10.5 | M10 | 30 | 2.5 |
| 13 | M12 | 37 | 3 |
| 15 | M14 | 44 | 3 |
| 17 | M16 | 50 | 3 |
| 20 | M18 | 56 | 4 |
| 22 | M20 | 60 | 4 |

DIN 440 FLAT WASHER

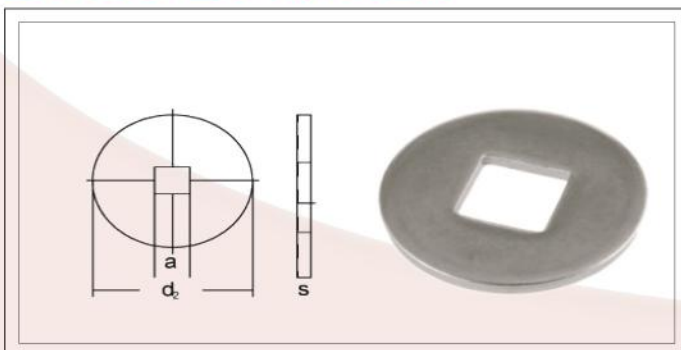

| a | Used for | d_2 | s |
|------|----------|-------|---|
| 5.5 | M5 | 18 | 2 |
| 6.6 | M6 | 22 | 2 |
| 9 | M8 | 28 | 3 |
| 11 | M10 | 34 | 3 |
| 13.5 | M12 | 44 | 4 |
| 17.5 | M16 | 56 | 5 |
| 22 | M20 | 72 | 6 |
| 24 | M22 | 80 | 6 |



DIN 127 SPRING LOCK WASHER

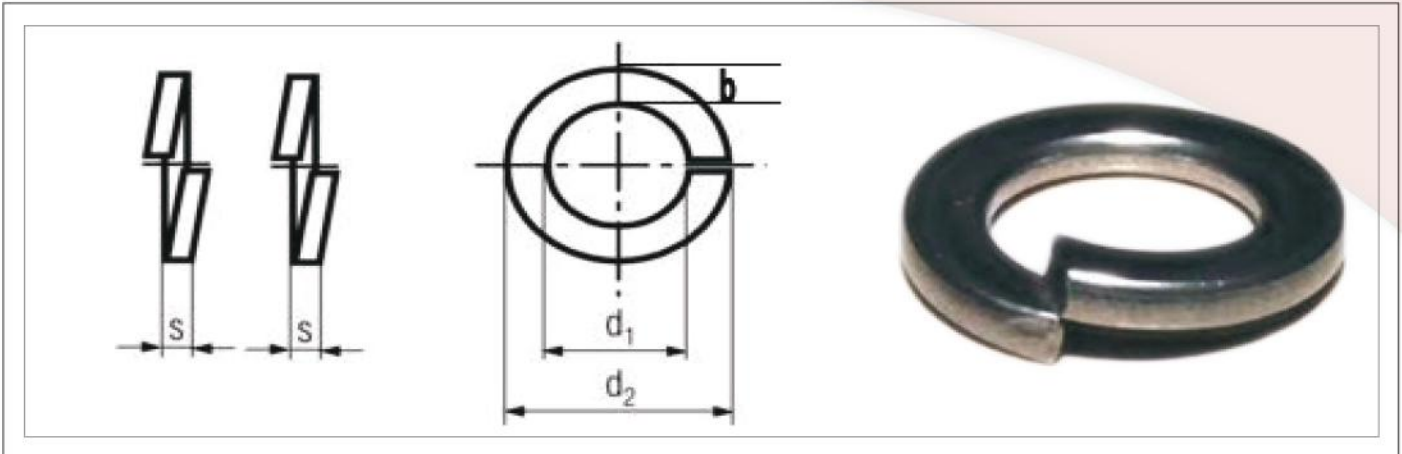

| d_1 | Used For | d_2 | b | s |
|-------|----------|-------|-----|-----|
| 2.1 | M2 | 4.4 | 0.9 | 0.5 |
| 2.4 | M2.3 | 4.9 | 1 | 0.6 |
| 2.6 | M2.5 | 5.1 | 1 | 0.6 |
| 3.1 | M3 | 6.2 | 1.3 | 0.8 |
| 3.6 | M3.5 | 6.7 | 1.3 | 0.8 |
| 4.1 | M4 | 7.6 | 1.5 | .09 |
| 5.1 | M5 | 9.2 | 1.8 | 1.2 |
| 6.1 | M 6 | 11.8 | 2.5 | 1.6 |
| 7.1 | M7 | 12.8 | 2.5 | 1.6 |
| 8.1 | M8 | 14.8 | 3 | 2 |
| 10.2 | M10 | 21.1 | 3.5 | 2.2 |
| 12.2 | M12 | 21.1 | 4 | 2.5 |
| 14.2 | M14 | 24.1 | 4.5 | 3 |
| 16.2 | M16 | 24.1 | 5 | 3.5 |
| 18.2 | M18 | 29.4 | 5 | 3.5 |
| 20.2 | M20 | 33.6 | 6 | 4 |
| 22.5 | M22 | 33.9 | 6 | 4 |
| 24.5 | M24 | 40 | 7 | 5 |
| 27.5 | M27 | 43 | 7 | 5 |
| 30.5 | M30 | 48.2 | 8 | 6 |
| 33.5 | M33 | 55.2 | 10 | 6 |
| 36.5 | M36 | 58.2 | 10 | 6 |
| 39 | M38 | 61.2 | 10 | 6 |
| 42.5 | M42 | 68.2 | 12 | 7 |
| 45.5 | M45 | 71.2 | 12 | 7 |
| 49 | M48 | 75 | 12 | 7 |
| 53 | M52 | 83 | 14 | 8 |
| 57 | M56 | 87 | 14 | 8 |
| 61 | M60 | 91 | 14 | 8 |
| 65 | M64 | 95 | 14 | 8 |
| 69 | M68 | 99 | 14 | 8 |
| 73 | M72 | 103 | 14 | 8 |
| 81 | M80 | 111 | 14 | 8 |
| 91 | M90 | 121 | 14 | 8 |
| 101 | M100 | 131 | 14 | 8 |



DIN 975 DIN 976 THREADED ROD







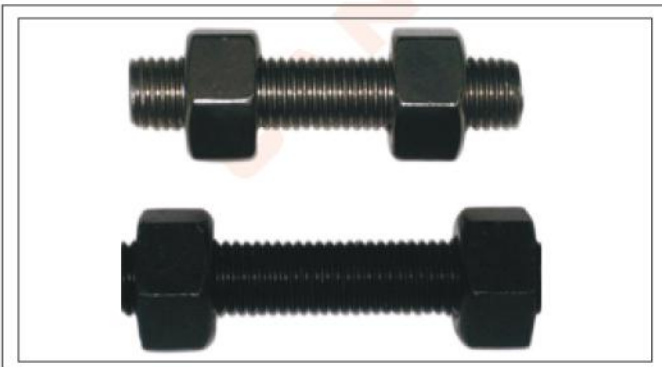









| SIZE | LENGTH | SIZE | LENGTH |
|------|--------------|------|--------------|
| M3 | 1-2 -3 meter | M24 | 1-2 -3 meter |
| M4 | 1-2 -3 meter | M27 | 1-2 -3 meter |
| M5 | 1-2 -3 meter | M30 | 1-2 -3 meter |
| M6 | 1-2 -3 meter | M33 | 1-2 -3 meter |
| M8 | 1-2 -3 meter | M36 | 1-2 -3 meter |
| M10 | 1-2 -3 meter | M39 | 1-2 -3 meter |
| M12 | 1-2 -3 meter | M42 | 1-2 -3 meter |
| M14 | 1-2 -3 meter | M45 | 1-2 -3 meter |
| M16 | 1-2 -3 meter | M48 | 1-2 -3 meter |
| M18 | 1-2 -3 meter | M52 | 1-2 -3 meter |
| M20 | 1-2 -3 meter | M56 | 1-2 -3 meter |
| M22 | 1-2 -3 meter | M64 | 1-2 -3 meter |

ASTM A193/B7 & NUT A194/2H STUD BOLT



| Size | Length |
|--------|--------------|
| 1/4" | 1-2 -3 meter |
| 5/16" | 1-2 -3 meter |
| 3/8" | 1-2 -3 meter |
| 7/16" | 1-2 -3 meter |
| 1/2" | 1-2 -3 meter |
| 9/16" | 1-2 -3 meter |
| 1/2" | 1-2 -3 meter |
| 9/16" | 1-2 -3 meter |
| 5/8" | 1-2 -3 meter |
| 3/4" | 1-2 -3 meter |
| 7/8" | 1-2 -3 meter |
| 1" | 1-2 -3 meter |
| 1-1/8" | 1-2 -3 meter |
| 1-1/4" | 1-2 -3 meter |
| 1-1/2" | 1-2 -3 meter |
| 1-3/8" | 1-2 -3 meter |
| 2" | 1-2 -3 meter |
| 2-1/4" | 1-2 -3 meter |
| 2-1/2" | 1-2 -3 meter |
| 3" | 1-2 -3 meter |
| 3-1/2" | 1-2 -3 meter |

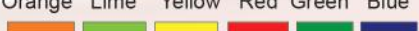

| | |
|--|---|
| <p>GLOVES</p>  | <p>Size -S,M,L,XL</p> <p>Quality - Terry, Vinyl, Nitriles, Kevlor, Neoprene</p> <p>Grip - Heat Resistent, Cotton Canvas, Chrome Canvas, Leather Gloves, Black Rubber & Electrician Gloves</p> <p>Colour Natural White Grey Brown Tan Blue</p>  |
| <p>SHOES</p>  | <p>Size -S,M,L,XL Colour-Natural, White, Grey Brown, Tan</p> <p>Quality - Steel Toe Rubber Boots in Black PVC & Steel Safety, Toe Disposable Latex Hazmat Boot Disposable, Polyethylene Color Natural White Grey Brown Tan</p> <p>Colour Natural White Grey Brown Tan</p>  |
| <p>COVERALLS</p>  | <p>Size S,M, L, XL</p> <p>Quality - Coverall with attached Hood & Boots, Antiskid attached boots, elastic waist, front zipper, clouserat chin Color - Orange Lime Yellow Red Green Blue</p> <p>Colour Orange Lime Yellow Red Green Blue</p>  |
| <p>HEADGEAR</p>  | <p>Size S,M, L, XL</p> <p>Quality - Coverall with attached Hood & Boots, Antiskid attached boots, elastic waist, front zipper, clouserat chin Color - Orange Lime Yellow Red Green Blue</p> <p>Colour Orange Lime Yellow Red Green Blue</p>  |
| <p>KNEE PADS</p>  | <p>Size - Standard</p> <p>Quality - Made of Moulded impact resistant rubber with adjustable straps which keeps the knees cushioned and dry against wet surfaces. Nubbed outside surface providing anti-slip benefit.</p> |
| <p>EYE PROTECTION</p>  | <p>Size - Standard</p> <p>Quality - Mono Goggle, large frame, anti fog over glass, perforate goggle with elastic straps, side shield</p> |
| <p>HARD HATS</p>  | <p>Size S,M, L, XL</p> <p>Quality - Heavy duty construction head protection meets applicable requirements of ANSI 7891.1 - 1997 Type I</p> |
| <p>JACKETS</p>  | <p>Size M-4XL-Size-S, M, L & XL</p> <p>Quality - Water proof wind breaker Jacket, outer shell made of 300 denier polyester with PU coating and polyester mesh lining available.</p> <p>Colour Orange Lime Yellow Red Green Blue</p>  |
| <p>SAFETY VEST</p>  | <p>Size S,M, L, XL</p> <p>Quality - Survey your safety vest, Fluorescent, 100% solid fabric, non conductive/</p> <p>Non-caustic zipper and multi pocket.</p> <p>Color Fluorescent Shades of Orange</p>  |

PACKAGING GUIDE



PRIMARY BOX



PRIMARY BOX



PLASTIC BOX PACKING



PALLET PACKING

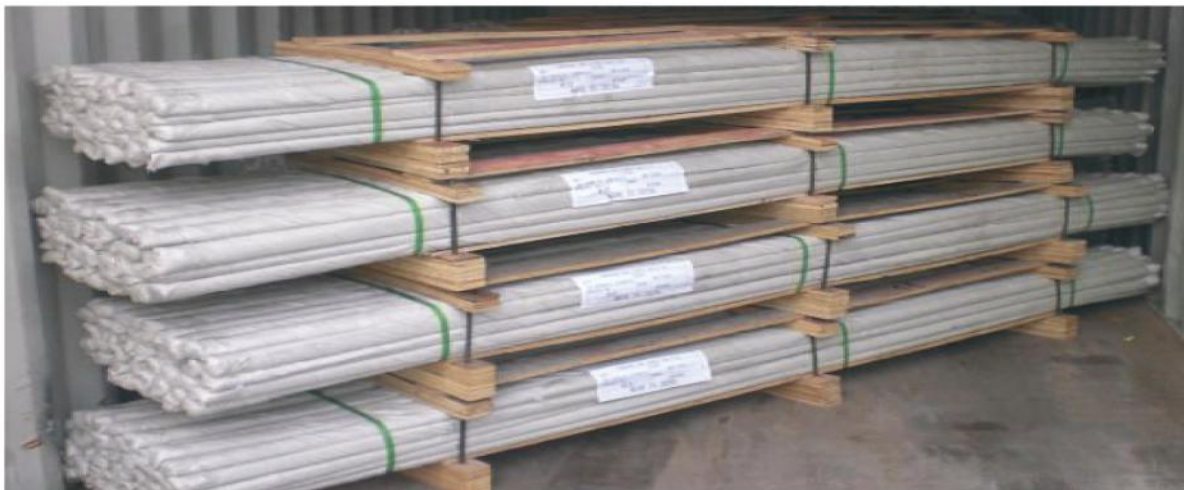

THREAD ROD PACKING



CARTON PACKING



BLISTER PACK